

## A Guide to Debouncing

August 2004

Rev 1: April, 2006

Rev 2: April, 2007

Rev 3: June, 2008

The beer warms a bit as you pound the remote control. Again and again, temper fraying, you click the "channel up" key until the TV finally rewards your efforts. But it turns out channel 345 is playing Jeopardy so you again wave the remote in the general direction of the set and continue fiddling with the buttons.

Some remotes work astonishingly well, even when you bounce the beam off three walls before it impinges on the TV's IR detector. Others don't. One vendor told me reliability simply isn't important as users will subconsciously hit the button again and again till the channel changes.

When a single remote press causes the tube to jump two channels, we developers know lousy debounce code is at fault. The FM radio on my sailboat has a tuning button that advances too far when I hit it hard. The usual suspect: bounce.

When the contacts of any mechanical switch bang together they rebound a bit before settling, causing bounce. Debouncing, of course, is the process of removing the bounces, of converting the brutish realities of the analog world into pristine ones and zeros. Both hardware and software solutions exist, though by far the most common are those done in a snippet of code.

Surf the net to sample various approaches to debouncing. Most are pretty lame. Few are based on experimental bounce parameters. A medley of anecdotal tales passed around the newsgroups substitute for empirical evidence.

Ask most developers about the characteristics of a bounce and they'll toss out a guess at a max bounce time. But there's an awful lot going on during the bounce. How can we build an effective bounce filter, in hardware or software, unless we understand the entire event? During that time a long and complex string of binary bits is hitting our code. What are the characteristics of that data?

We're writing functions that process an utterly mysterious and unknown input string. That's hardly the right way to build reliable code.

### The Data

So I ran some experiments.

I pulled some old switches out of my junk box. 20 bucks at the ever-annoying local Radio Shack yielded more (have you noticed that Radio Shack has fewer and fewer components? It's getting hard to buy a lousy NPN transistor there). Baynesville Electronics (<http://www.baynesvilleelectronics.com>), Baltimore's best electronics store, proved a switch treasure trove. Eventually I had 18 very different kinds of switches.

My desktop PC always has a little \$49 MSP430 (TI's greatly underrated 16 bit microprocessor) development board attached, with IAR's toolchain installed. It's a matter of seconds to pop a little code into the board and run experiments. Initially I'd planned to connect each switch to an MSP430 input and have firmware read and report bounce parameters. A bit of playing around with the mixed signal scope (MSO) showed this to be an unwise approach.

I gave up regular oscilloscopes long ago; now my Agilent 54645D MSO is a trusty assistant that peers deep into electronic systems. An MSO is both logic analyzer and o-scope, all in one. Trigger from either an analog channel or a digital pattern to start the trace. The MSO shows, like no other instrument, the relationship between the real world and our digital instantiation of it.

Many of the switches exhibited quite wild and unexpected behavior. Bounces of under 100 nsec were common (more on this later). No reasonable micro could reliably capture these sorts of transitions, so I abandoned that plan and instead used the scope, connecting both analog and digital channels to the switch. This let me see what was going on in the analog domain, and how a computer would interpret the data. A 5 volt supply and 1k pull-up completed the test jig.

If a sub-100 nsec transition won't be captured by a computer why worry about it? Unfortunately, even a very short signal will toggle the logic once in a while. Tie it to an interrupt and the likelihood increases. Those transitions, though very short, will occasionally pervert the debounce routine. For the sake of the experiment we need to see them.

I tested the trigger switches from an old cheap game-playing joystick (the three yellow ones in the picture), the left mouse button from an ancient Compaq computer (on PCB in upper left corner), toggle switches, pushbuttons, and slide switches. Some were chassis mount, others were to be soldered directly onto circuit boards.



*Switches tested. The upper left is switch A, with B to its right, working to E (in red), and then F below A, etc.*

I pressed each switch 300 times, logging the min and max amount of bouncing for both closing and opening of the contacts. Talk about mind-numbingly boring! I logged every individual bounce time for each actuation into a spreadsheet for half the switches till my eyes glazed over and gentle wife wondered aloud if I was getting some sort of Pavlovian reward.

The results were interesting.

### **Bounce Stats**

So how long do switches bounce for? The short answer: sometimes a lot, sometimes not at all.

Only two switches exhibited bounces exceeding 6200  $\mu$ sec. Switch E, what seemed like a nice red pushbutton, had a worst case bounce when it opened of 157 msec - almost a 1/6 of a second! Yuk. Yet it never exceeded a 20  $\mu$ sec bounce when closed. Go figure.

Another switch took 11.3 msec to completely close one time; other actuations were all under 10 msec.

Toss out those two samples and the other 16 switches exhibited an average 1557  $\mu$ sec of bouncing, with, as I said, a max of 6200  $\mu$ sec. Not bad at all.

Seven of the switches consistently bounced much longer when closed than when opened. I was amazed to find that for most of the switches many bounces on opening lasted for less than 1  $\mu$ sec - that's right, less than a millionth of a second. Yet the very next experiment on the same switch could yield a reading in the hundreds of microseconds.

Identical switches were not particularly identical. Two matching pairs were tested; each twin differed from its brother by a factor of two.

Years ago a pal and I installed a system for the Secret Service that had thousands of very expensive switches on panels in a control room. We battled with a unique set of bounce challenges because the uniformed officers were too lazy to stand up and press a button. They tossed rulers at the panels from across the room. Different impacts created (and sometimes destroyed, but hey, it's only taxpayer money after all) quite an array of bouncing. So in these experiments I tried to actuate each device with a variety of techniques. Pushing hard or soft, fast or slow, releasing gently or with a snap, looking for different responses. F, a slide switch, was indeed very sensitive to the rate of actuation. Toggle switch G showed a 3 to 1 difference in bounce times depending on how fast I bonked its lever. A few others showed similar results but there was little discernable pattern.

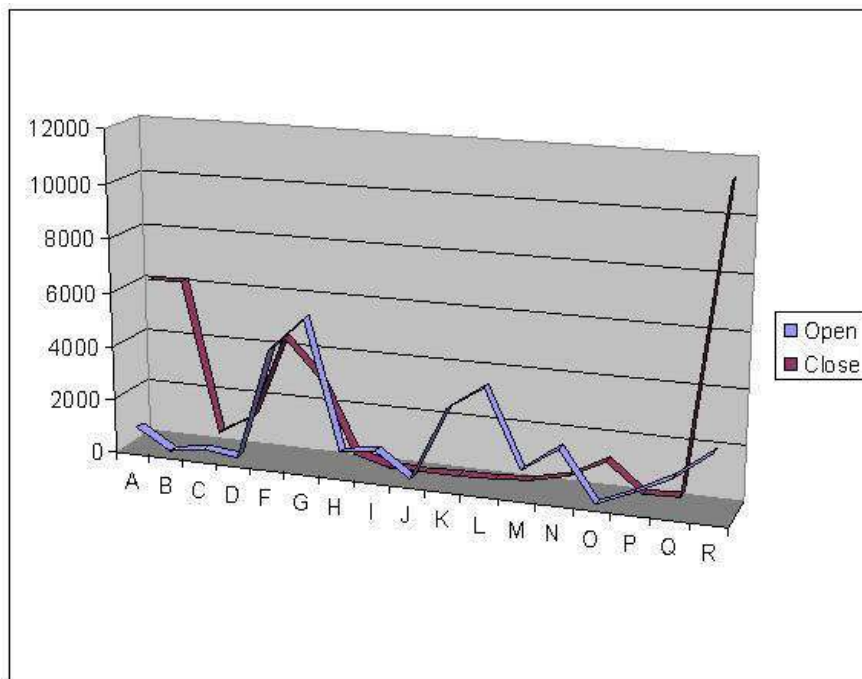

*Bounce times in microseconds, for opening and closing each switch (number A to R). Switch E was left out, as its 157 msec bounces would horribly skew the graph.*

I was fascinated with the switches' analog behavior. A few operated as expected, yielding a solid zero or 5 volts. But most gave much more complicated responses.

The MSO responded to digital inputs assuming TTL signal levels. That means 0 to .8 volts is a zero, 0.8 to 2.0 is unknown, and above 2 a one. The instrument displayed both digital and analog signals to see how a logic device would interpret the real-world's grittiness.

Switch A was typical. When opened the signal moved just a bit above ground and wandered in the hundreds of millivolts range for up to 8 msec. Then it suddenly snapped to a one. As the signal meandered up to near a volt the scope interpreted it as a one, but the analog's continued uneasy rambles took it in and out of "one" territory. The MSO showered the screen with hash as it tried to interpret the data.

It was if the contacts didn't bounce so much as wiped, dragging across each other for a time, acting like a variable resistor.

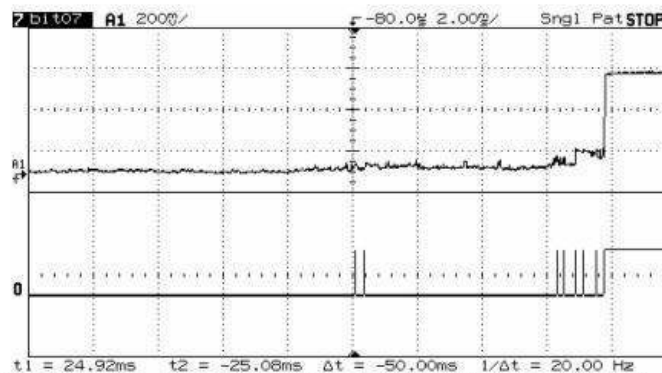

*Switch A at 2 msec/div. Note 8 msec of unsettled behavior before it finally decides to open.*

Looking into this more deeply I expanded the traces for switch C and, with the help of Ohm's Law, found the resistance when the device opened crawled pretty uniformly over 150  $\mu$ sec from zero to 6 ohms, before suddenly hitting infinity. There was no bouncing per se; just an uneasy ramp up from 0 to 300 mV before it suddenly zapped to a solid +5.

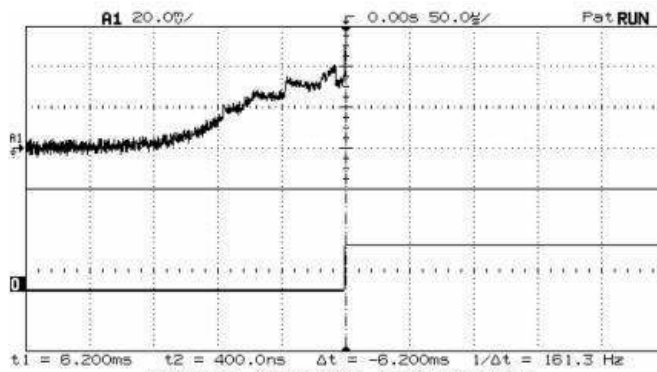

*Switch C - 50  $\mu$ sec/div and 200 mV/div.*

Another artifact of this wiping action was erratic analog signals treading in the dreaded no-man's land of TTL uncertainty (0.8 to 2.0 volts), causing the MSO to dither, tossing out ones or zeroes almost randomly, just as your microprocessor would if connected to the same switch.

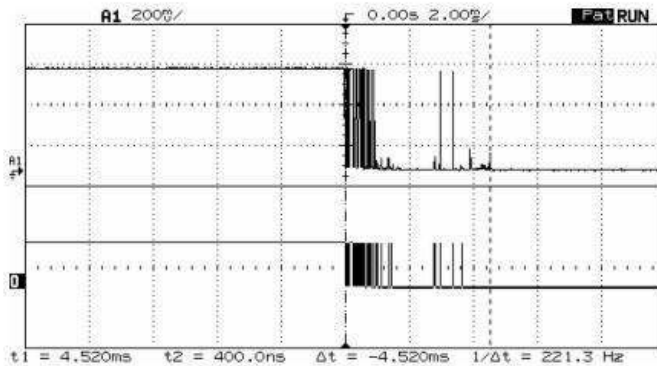

*Switch B - note how the analog peak to the right didn't quite trigger the logic channel.*

The two from the el cheapo game joystick were nothing more than gold contacts plated onto a PCB; a rubber cover, when depressed, dropped some sort of conductive elastomer onto the board. Interestingly, the analog result was a slow ramp from zero to five volts, with no noise, wiping or other uncertainty. Not a trace of bounce. And yet... the logic channel showed a msec or so of wild oscillations! What's going on?

With TTL logic, signals in the range of 0.8 to 2.0 volts are illegal. Anything goes, and everything did. Tie this seemingly bounce-free input to your CPU and prepare to deal with tons of oscillation - virtual bounces.

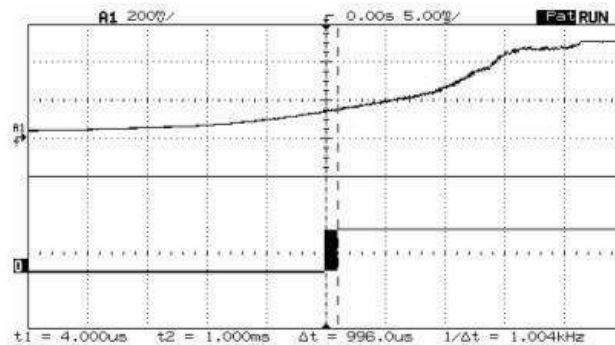

*Switch K at 5 msec/div - which slowly ramps up and down when actuated. Cool!*

My assessment, then, is that there's much less whacking of contacts going on than we realize. A lot of the apparent logic hash is from analog signals treading in illegal logic regions. Regardless, the effect on our system is the same and the treatment identical. But the erratic nature of the logic warns us to avoid simple sampling algorithms, like assuming two successive reads of a one means a one.

### Anatomy of a Bounce

So we know how long the contacts bounce and that lots of digital zaniness - ultra short pulses in particular - can appear.

But what happens during the bounce? Quite a lot, and every bounce of every switch was different. Many produced only high speed hash till a solid one or zero appeared. Others generated a serious pulse train of discernable logic levels like one might expect. I was especially interested in results that would give typical debounce routines heartburn.

Consider switch E again, that one with the pretty face that hides a vicious 157 msec bouncing heart. One test

showed the switch going to a solid one for 81 msec, after which it dropped to a perfect zero for 42 msec before finally assuming its correct high state. Think what that would do to pretty much any debounce code!

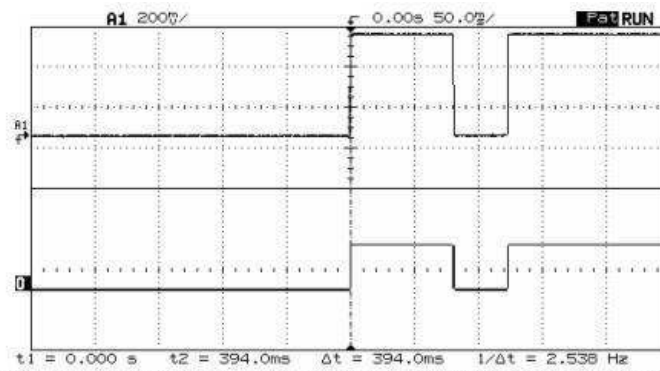

*Switch E again, at 50 msec/div. Do you have blood pressure problems? You will after writing code to debounce this!*

Switch G was pretty well behaved, except that a couple of times it gave a few microsecond one before falling to zero for over 2 msec. Then it assumed its correct final one. The initial narrow pulse might escape your polled I/O, but would surely fire off an interrupt, had you dared wire the system so. The poor ISR would be left puzzled as it contemplates 2 msec of nothingness. "Me? Why did it invoke me? Ain't nuthin' there!"

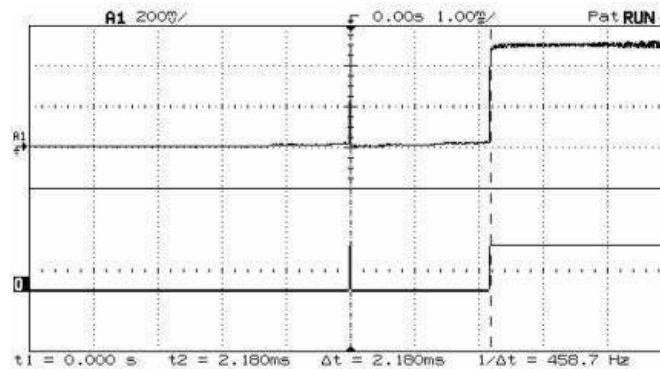

*Switch G. One super narrow pulse followed by 2 msec of nothingness. A sure-fire ISR confuser.*

O is a very nice, high quality microswitch which never showed more than 1.18 msec of bouncing. But digging deeper I found it usually generated a pulse train guaranteed to play havoc with simple filter code. There's no high speed hash, just hard-to-eliminate solid ones and zeroes. One actuation yielded 7 clean zeroes levels ranging in time from 12 to 86 µsec, and 7 logic ones varying from 6 to 95 µsec. Easy to filter? Sure. But not by code that just looks for a couple of identical reads.

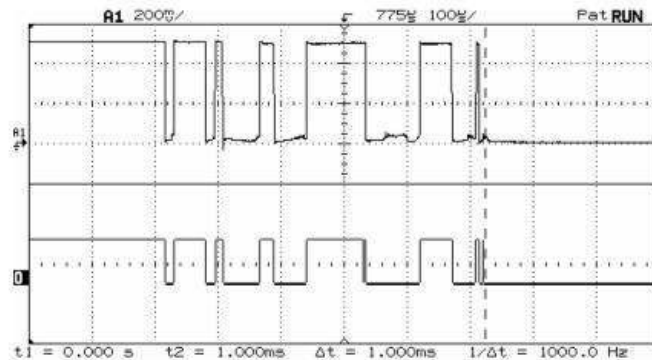

*Switch O, which zaps around enough to confuse dumb debouncers.*

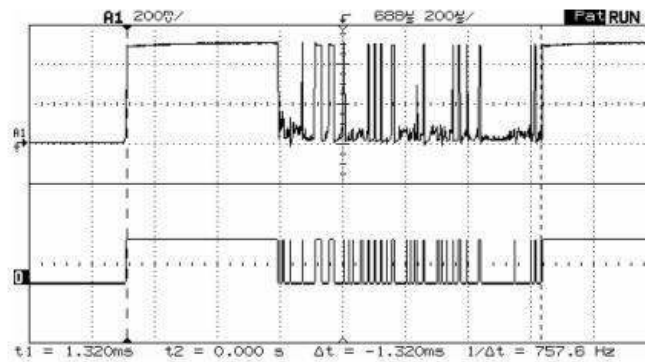

*Switch Q – when released, it goes high for 480  $\mu\text{sec}$  before generating 840  $\mu\text{sec}$  of hash, a sure way to blow an interrupt system mad if poorly designed.*

What happens if we press the buttons really, really fast? Does that alter the bouncing in a significant way? It's awfully hard for these 50 year old fingers to do anything particularly quickly, so I set up a modified experiment, connecting my MSP430 board to a sizeable 3 amp four pole relay. Downloading code into the CPU's flash let me toggle the relay at different rates.

Bounce times ranged from 410 to 2920  $\mu\text{sec}$ , quite similar to those of the switches, presumably validating the experiment. The relay had no noticeable analog effects, banging cleanly between 0 and 5 volts.

The raucous clacking of contacts overwhelmed our usual classical fare for a few hours as the MSO accumulated bounce times in storage mode. When the relay opened it always had a max bounce time of 2.3 to 2.9 msec, at speeds from 2.5 to 30 Hz. More variation appeared on contact closure: at 2.5 Hz bounces never exceeded 410  $\mu\text{sec}$ , which climbed to 1080  $\mu\text{sec}$  at 30 Hz. Why? I have no idea. But it's clear there is some correlation between fast actuations and more bounce. These numbers suggest a tractable factor of two increase, though, not a scary order of magnitude or more.

In the bad old days we used a lot of leaf switches which typically bounced forever. Weeks, it seemed. Curious I disassembled a number of cheap consumer products expecting to find these sort of inexpensive devices. None found! Now that everything is mounted on a PCB vendors use board-mounted switches, which are pretty darn good little devices.

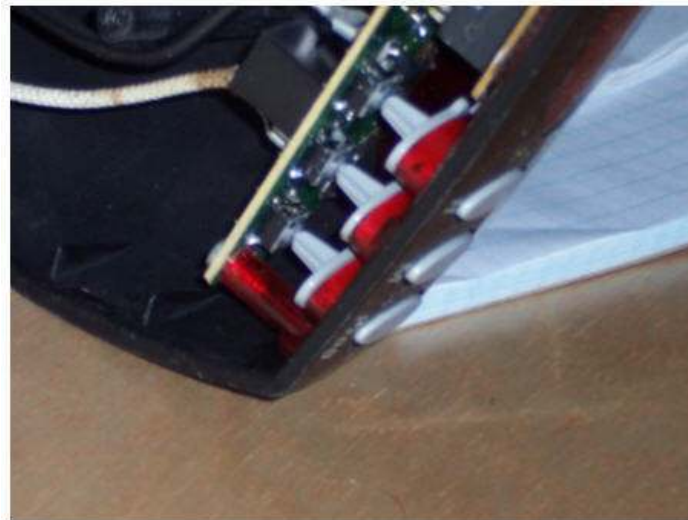

*PCB switches in a cheap coffee maker.*

I admit these experiments aren't terribly scientific. No doubt someone with a better education and more initials following his name could do a more reputable study for one of those journals no one reads. But as far as I know there's no data on the subject available anywhere, and we working engineers need some empirical information.

Use a grain of salt when playing with these numbers. Civil engineers don't really know the exact strength of a concrete beam poured by indolent laborers, so they beef things up a bit. They add margin. Do the same here. Assume things are worse than shown.

## Hardware Debouncers

Figure 1 shows the classic debounce circuit. Two cross-coupled NAND gates form a very simple Set-Reset (SR) latch. The design requires a double-throw switch. Two pull-up resistors generate a logic one for the gates; the switch pulls one of the inputs to ground.

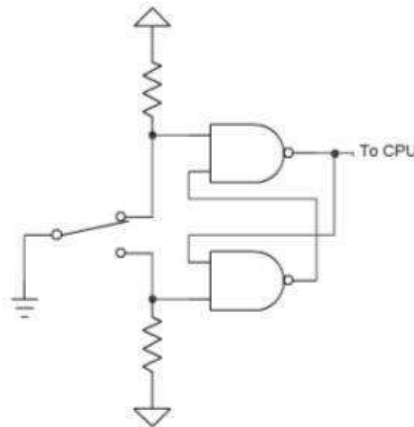

*Figure 1: The SR debouncer*

The SR latch is a rather funky beast, as confusing to non-EEs as recursion is to, well, just about everyone.

With the switch in the position shown the upper gate's output will be a one, regardless of the value of the other input. That and the one created by the bottom pull-up resistor drives the lower NAND to a zero . . . which races around back into the other gate. If the switch moves between contacts, and is for a while suspended in the nether region between terminals, the latch maintains its state because of the looped back zero from the bottom gate.

The switch moves a rather long way between contacts. It may bounce around a bit, but will never bang all the way back to the other contact. Thus, the latch's output is guaranteed bounce-free.

The circuit suggests an alternative approach, a software version of the same idea. Why not skip the NAND pair and run the two contacts, with pull-ups, directly to input pins on the CPU? Sure, the computer will see plenty of bounciness, but write a trivial bit of code that detects *any* assertion of either contact. which means the switch is in that position, as follows:

```
if (switch_hi ()) state=ON;  
if (switch_lo ()) state=OFF;
```

`switch_hi` and `switch_lo` each reads one of the two throws. Other functions in the program examine variable `state` to determine the switch's position.

This saves two gates but costs one extra input pin on the processor. It's the simplest - and most reliable - debounce code possible.

The MC14043/14044 chips consist of four SR flip flops, so might be an attractive solution for debouncing multiple switches. A datasheet can be found at <http://www.radanpro.com/el/dslpro.php?MC14043.pdf>

are bulkier and more expensive than the simpler single-throw versions. An awful lot of us use switches that are plated onto the circuit board, and it's impossible to make DP versions of these. So EEs prefer alternative designs that work with cheap single-throw switches.

Though complex circuits using counters and smart logic satisfy our longing for pure digital solutions to all problems, from signal processing to divorce, it's easier and cheaper to exploit the peculiar nature of a resistor-capacitor (RC) network.

Charge or discharge a capacitor through a resistor and you'll find the voltage across the cap rises slowly; it doesn't snap to a new value like a sweet little logic circuit. Increase the value of either component and the time lag ("time constant" in EE lingo) increases.

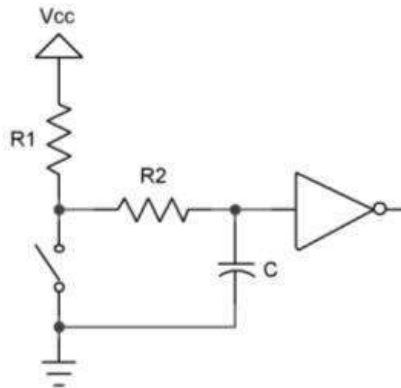

*Figure 2: An RC debouncer*

Figure 2 shows a typical RC debouncer. A simple circuit, surely, yet one that hides a surprising amount of complexity.

Suppose our fearless flipper opens the switch. The voltage across the cap is zero, but it starts to climb at a rate determined by the values of  $R_1$ ,  $R_2$  and  $C$ . Bouncing contacts pull the voltage down and slow the cap's charge accumulation. If we're very clever in selecting the values of the components the voltage stays below a gate's logic one level till all of the whacking and thudding ceases. (If the time constant is too long, of course, the system won't be responsive to fast switch actuations).

The gate's output is thus a pristine bounce-free logic level.

Now suppose the switch has been open for a while. The cap is fully charged. Snap! The user closes the switch, which discharges the cap through  $R_2$ . Slowly, again, the voltage drools down and the gate continues to see a logic one at its input for a time. Perhaps the contacts open and close a bit during the bouncing. While open, even if only for short periods, the two resistors start to recharge the cap, reinforcing the logic one to the gate. Again, the clever designer selects component values that guarantee the gate sees a one until the clacking contacts settle.

Squalid taverns are filled with grizzled veterans of the bounce wars recounting their circuits and tales of battles in the analog trenches. Most will puzzle over  $R_2$ , and that's not entirely due to the effects of the cheap booze. The classic RC debouncer doesn't use this resistor, yet it's critically important to getting a thwack-free output from the gate.

$R_2$  serves no useful purpose when the switch opens.  $R_1$  and  $C$  effectively remove those bounces. But strange things can happen when suddenly discharging a capacitor. The early bouncing might be short, lasting microseconds or less. Though a dead short should instantly discharge the cap, there are no pristine conditions in the analog world. The switch has some resistance, as do the wires and PCB tracks that interconnect everything.

Every wire is actually a complex circuit at high speeds. You wouldn't think a dull-headed customer flipping the switch a few times a second would be generating high-speed signals, but sub-microsecond bounces, which may have very sharp rise times, have frequency components in the tens of MHz or more. Inductance and stray capacitance raises the impedance (AC resistance) of the closed switch. The cap won't instantly discharge.

Worse, depending on the physical arrangement of the components, the input to the gate might go to a logic zero while the voltage across the cap is still one-ish. When the contacts bounce open the gate now sees a one. The output is a train of ones and zeroes - bounces.

$R_2$  insures the cap discharges slowly, giving a clean logic level regardless of the storm of bounces. The resistor also limits current flowing through the switch's contacts, so they aren't burned up by a momentary major surge of electrons from the capacitor.

Another trick lurks in the design. The inverter cannot be a standard logic gate. TTL, for instance, defines a zero as an input between 0.0 and 0.8 volts. A one starts at 2.0. In between is a DMZ which we're required to avoid. Feed 1.2 volts to such a gate and the output is unpredictable. But this is exactly what will happen as the cap charges and discharges.



Instead use a device with "Schmitt Trigger" inputs. These devices have hysteresis; the inputs can dither yet the output remains in a stable, known state.

Never run the cap directly to the input on a microprocessor, or to pretty much any I/O device. Few of these have any input hysteresis.

## Doing The Math

The equation for discharging a cap is:

$$V_{cap} = V_{initial} (e^{-\frac{t}{RC}})$$

where

$V_{cap}$  is the voltage across the capacitor at time  $t$ ,

$V_{initial}$  is the voltage initially on the cap,

$t$  is the time in seconds,

$R$  and  $C$  are the values of the resistor and capacitor in ohms and farads, respectively.

The trick is to select values that insure the cap's voltage stays above  $V_{th}$ , the threshold at which the gate switches, till the switch stops bouncing. It's surprising how many of those derelicts hanging out at the waterfront bars pick an almost random time constant. "The boys 'n me, we jest figger sumpin like 5 msec". Shortchanging a real analysis starts even a clean-cut engineer down the slippery slope to the wastrel vagabond's life.

Most of the switches I examined last month had bounce times well under 10 msec. Use 20 to be conservative.

Rearranging the time constant formula to solve for R (the cost and size of caps vary widely so it's best to select a value for C and then compute R) yields:

$$R = \frac{-t}{C \ln\left(\frac{V_{th}}{V_{initial}}\right)}$$

Though it's an ancient part, the 7414 hex inverter is a Schmitt Trigger with great input hysteresis. The AHCT version has a worst case  $V_{th}$  for a signal going low of 1.7 volts. Let's try 0.1  $\mu$ F for the capacitor since those are small and cheap, and solve for the condition where the switch just closes. The cap discharges through  $R_2$ . If the power supply is 5 volts (so  $V_{initial}$  is 5), then  $R_2$  is 185K. Of course, you can't actually *buy* that kind of resistor, so use 180K.

But, the analysis ignores the gate's input leakage current. A CMOS device like the 74AHCT14 dribbles about a microamp from the inputs. That 180K resistor will bias the input up to .18 volts, uncomfortably close to the gate's best-case switching point of 0.5 volt. Change C to 1  $\mu$ F and  $R_2$  is now 18K.

$R_1 + R_2$  controls the cap's charge time, and so sets the debounce period for the condition where the switch opens. The equation for charging is:

$$V_{th} = V_{final} (1 - e^{-t/RC})$$

Solving for R:

$$R = \frac{-t}{C \ln\left(1 - \frac{V_{th}}{V_{final}}\right)}$$

$V_{final}$  is the final charged value - the 5 volt power supply.  $V_{th}$  is now the worst-case transition point for a high-going signal, which for our 74AHCT14 a peachy 0.9 volts.  $R_1 + R_2$  works out to 101K. Figure on 82K (a standard part) for  $R_1$ .

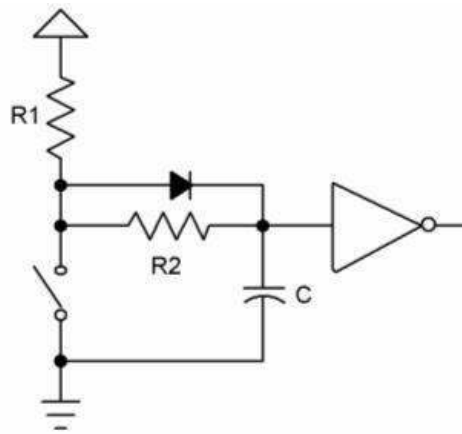

Figure 3: An RC debouncer that actually works in all cases

The diode is an optional part needed only when the math goes haywire. It's possible, with the wrong sort of gate where the hysteresis voltages assume other values, for the formulas to pop out a value for  $R_1 + R_2$  which is less than that of  $R_2$ . In this case the diode forms a short cut that removes  $R_2$  from the charging circuit. All of the charge flows through  $R_1$ . The previous equation still applies, except we have to account for drop across the diode. Change  $V_{final}$  to 4.3 volts (5 minus the 0.7 diode drop), turn the crank and  $R_1$  pops out.

Be wary of the components' tolerances. Standard resistors are usually  $\pm 5\%$ . Capacitors vary wildly -  $+80/-20\%$  is a common rating for electrolytics. Even small ceramics might vary  $\pm 30\%$ .

### Other Thoughts

Don't neglect to account for the closed resistance of oddball switches. Some conductive elastomer devices exceed 200 ohms.

Two of the elastomer switches I examined last month didn't bounce at all; their output smoothly ramped from zero to +5 volts. The SR and RC debounce circuits are neither necessary nor effective. Better: run the switch directly into a Schmitt Trigger's input.

Never connect an undebounced switch to the clock of a flip-flop. The random bounce hash is sure to confuse the device. A 74HCT74 has a max rise and fall time spec of 6 nsec - easily exceeded by some of the data I acquired from the 18 switches tested.

The 74HC109 requires a minimum clock width of 100 nsec. I found pulses shorter than this in my experiments. Some of these parts, like from Philips, have a Schmitt Trigger clock input - it's a much safer part to use when connected to real-world events.

Similarly, don't tie undebounced switches, even if Schmitt Triggered, to interrupt inputs on the CPU. Usually the interrupt pin goes to the clock input of an internal flip flop. As processors become more complex their datasheets give less useful electrical information; they're awash in programming data but leave designers adrift without complete timing specs. Generally we have no idea what the CPU expects as a max rise time or the min pulse width. Those internal flops aren't perfect, so don't flirt with danger by feeding them garbage.

The MC14490 is a cool chip that consists of 6 debouncers. A datasheet is at <http://engineering.dartmouth.edu/~engs031/databook/mc14490.pdf>. But in August of 2004 Digikey wants \$5.12 each for these parts; it's cheaper to implement a software debounce algorithm in a PIC or similar sub-\$1 microcontroller.

Always remember to tie unused inputs of any logic circuit to Vcc or ground.

### Software Debouncers

Software debounce routines range from the utterly simple to sophisticated algorithms that handle multiple switches in parallel. But many developers create solutions without completely understanding the problem. Sure, contacts rebound against each other. But the environment itself can induce all sorts of short transients that mask themselves as switch transitions. Called EMI (electromagnetic interference), these bits of nastiness come from energy coupled into our circuits from wires running to the external world, or even from static electricity zaps induced by shuffling feet across a dry carpet. Happily EMI and contact whacking can be cured by a decent debounce routine. . . . but both factors do affect the design of the code.

Consider the simplest of all debouncing strategies: read the switch once every 500 msec or so, and set a flag indicating the input's state. No reasonable switch will bounce that long. A read during the initial bounce period returns a zero or a one indicating the switch's indeterminate state. No matter how we interpret the data (i.e., switch on or off) the result is meaningful. The slow read rate keeps the routine from deducing that bounces are multiple switch closures. One downside, though, is slow response. If your user won't hit buttons at a high rate this is probably fine. A fast typist, though, can generate 100 words per minute or almost 10 characters per second. A rotating mechanical encoder could generate even faster transitions.

But there's no EMI protection inherent in such a simple approach. An application handling contacts plated onto the PCB is probably safe from rogue noise spikes, but one that reads from signals cabled onto the board needs more sophisticated software, since a single glitch might look like a contact transition.

It's tempting to read the input a couple of times each pass through the 500 msec loop and look for a stable signal. That'll reject much or maybe all of the EMI. But some environments are notoriously noisy. Many years ago I put a system using several Z80s and a PDP-11 in a steel mill. A motor the size of a house drawing thousands of amps drove the production line. It reversed direction every few seconds. The noise generated by that changeover coupled *everywhere*, and destroyed everything electronic unless carefully protected. We optocoupled all cabling simply to keep the smoke inside the ICs, where it belongs. All digital inputs still looked like hash and needed an astonishing amount of debounce and signal conditioning.

## Debounce Policy

Seems to me there are some basic constraints to place on our anti-contact-clacking routines. Minimize CPU overhead. Burning execution time while resolving a bounce is a dumb way to use processor cycles. Debounce is a small problem and deserves a small part of the computer's attention.

The undebounced switch must connect to a programmed I/O pin, never to an interrupt. Few microprocessor datasheets give much configuration or timing information about the interrupt inputs. Consider Microchip's PIC12F629 (datasheet at <http://ww1.microchip.com/downloads/en/DeviceDoc/41190c.pdf>). A beautiful schematic shows an interrupt pin run through a Schmitt Trigger device to the data input of a pair of flops. Look closer and it's clear that's used only for one special "interrupt on change" mode. When the pin is used as a conventional interrupt the signal disappears into the bowels of the CPU, sans hysteresis and documentation. However, you can count on the interrupt driving the clock or data pin on an internal flip flop. The bouncing zaniness is sure to confuse any flop, violating minimum clock width or the data setup and hold times.

Try to avoid sampling the switch input at a rate synchronous to events in the outside world that might create periodic EMI. For instance, 50 and 60 Hz are bad frequencies. Mechanical vibration can create periodic interference. I'm told some automotive vendors have to avoid sampling at a rate synchronous to the vibration of the steering column.

Finally, in most cases it's important to identify the switch's closure quickly. Users get frustrated when they take an action and there's no immediate response. You press the button on the gas pump or the ATM and the machine continues to stare at you, dumbly, with the previous screen still showing, till the brain-dead code finally gets around to grumpily acknowledging that, yes, there IS a user out there and the person actually DID press a button.

Respond *instantly* to user input. In this fast-paced world delays aggravate and annoy. But how fast is fast enough?

I didn't know so wired a switch up to the cool R3000 starter kit Rabbit Semiconductor provides. This board and software combo seems targeted at people either learning embedded programming or those of us who just like to play with electronical things. I wrote a bit of simple code to read a button and, after a programmable delay, turn on an LED. Turns out a 100 msec delay is quite noticeable, even to these tired old 20/1000 eyes. 50 msec, though, seemed instantaneous. Even the kids concurred, astonishing since it's so hard to get them to agree on anything.

So let's look at a couple of debouncing strategies.

## A Counting Algorithm

Most people use a fairly simple approach that looks for  $n$  sequential stable readings of the switch, where  $n$  is a number ranging from 1 (no debouncing at all) to seemingly infinity. Generally the code detects a transition and then starts incrementing or decrementing a counter, each time rereading the input, till  $n$  reaches some presumably safe, bounce-free, count. If the state isn't stable, the counter resets to its initial value.

Simple, right? Maybe not. Too many implementations need some serious brain surgery. For instance, use a delay so the repetitive reads aren't back to back, merely microseconds apart. Unless your application is so minimal there are simply no free resources, don't code the delay using the classic construct: `for (i=0; i<big_number;++i);`. Does this idle for a millisecond. or a second? Port the code to a new compiler or CPU, change wait states or the clock rate and suddenly the routine breaks, requiring manual tweaking. Instead use a timer that interrupts the CPU at a regular rate - maybe every millisecond or so - to sequence these activities.

Listing 1 shows a sweet little debouncer that is called every CHECK\_MSEC by the timer interrupt, a timer-initiated task, or some similar entity.

```

#define CHECK_MSEC    5    // Read hardware every 5 msec
#define PRESS_MSEC    10   // Stable time before registering pressed
#define RELEASE_MSEC 100  // Stable time before registering released

// This function reads the key state from the hardware.
extern bool_t RawKeyPressed();

// This holds the debounced state of the key.
bool_t DebouncedKeyPress = false;

// Service routine called every CHECK_MSEC to
// debounce both edges
void DebounceSwitch1(bool_t *Key_changed, bool_t *Key_pressed)
{
    static uint8_t Count = RELEASE_MSEC / CHECK_MSEC;
    bool_t RawState;
    *Key_changed = false;
    *Key_pressed = DebouncedKeyPress;
    RawState = RawKeyPressed();
    if (RawState == DebouncedKeyPress) {
        // Set the timer which allows a change from current state.
        if (DebouncedKeyPress) Count = RELEASE_MSEC / CHECK_MSEC;
        else Count = PRESS_MSEC / CHECK_MSEC;
    } else {
        // Key has changed - wait for new state to become stable.
        if (--Count == 0) {
            // Timer expired - accept the change.
            DebouncedKeyPress = RawState;
            *Key_changed=true;
            *Key_pressed=DebouncedKeyPress;
            // And reset the timer.
            if (DebouncedKeyPress) Count = RELEASE_MSEC / CHECK_MSEC;
            else Count = PRESS_MSEC / CHECK_MSEC;
        }
    }
}

```

*Listing 1: A simple yet effective debounce algorithm*

You'll notice there are no arbitrary count values; the code doesn't wait for  $n$  stable states before declaring the debounce over. Instead it's all based on time and is therefore eminently portable and maintainable.

DebounceSwitch1() returns two parameters. Key\_Pressed is the current debounced state of the switch. Key\_Changed signals the switch has changed from open to closed, or the reverse.

Two different intervals allow you to specify different debounce periods for the switch's closure and its release. To minimize user delays why not set PRESS\_MSEC to a relatively small value, and RELEASE\_MSEC to something higher? You'll get great responsiveness yet some level of EMI protection.

### An Alternative

An even simpler routine, shown in figure 2, returns TRUE once when the debounced leading edge of the switch closure is encountered. It offers protection from both bounce and EMI.

```

// Service routine called by a timer interrupt
bool_t DebounceSwitch2()
{
    static uint16_t State = 0; // Current debounce status
    State=(State<<1) | !RawKeyPressed() | 0xe000;
    if(State==0xf000)return TRUE;
    return FALSE;
}

```

*Listing 2: An even simpler debounce routine*

Like the routine in listing 1, DebounceSwitch2() gets called regularly by a timer tick or similar scheduling mechanism. It shifts the current raw value of the switch into variable State. Assuming the contacts return zero for a closed condition, the routine returns FALSE till a dozen sequential closures are detected.

One bit of cleverness lurks in the algorithm. As long as the switch isn't closed ones shift through State. When the user pushes on the button the stream changes to a bouncy pattern of ones and zeroes, but at some point there's the last bounce (a one) followed by a stream of zeroes. We OR in 0xe000 to create a "don't care" condition in the upper bits. But as the button remains depressed State continues to propagate zeroes. There's just the one time, when the last bouncy "one" was in the upper bit position, that the code returns a TRUE. That bit of wizardry eliminates bounces and detects the edge, the transition from open to closed.

Change the two hex constants to accommodate different bounce times and timer rates.

Though quite similar to a counting algorithm this variant translates much more cleanly into assembly code. One reader implemented this algorithm in a mere 11 lines of 8051 assembly language.

Want to implement a debouncer in your FPGA or ASIC? This algorithm is ideal. It's loopless and boasts but a single decision, one that's easy to build into a single wide gate.

### Handling Multiple Inputs

Sometimes we're presented with a bank of switches on a single input port. Why debounce these individually when there's a well-known (though little used) algorithm to handle the entire port in parallel?

Figure 3 shows one approach. `DebounceSwitch()`, which is called regularly by a timer tick, reads an entire byte-wide port that contains up to 8 individual switches. On each call it stuffs the port's data into an entry in circular queue `State`. Though shown as an array with but a single dimension, a second loiters hidden in the width of the byte. `State` consists of columns (array entries) and rows (each defined by bit position in an individual entry, and corresponding to a particular switch).

```
#define MAX_CHECKS 10      // # checks before a switch is debounced
uint8_t Debounced State; // Debounced state of the switches
uint8_t State[MAX_CHECKS]; // Array that maintains bounce status
uint8_t Index;           // Pointer into State

// Service routine called by a timer interrupt
void DebounceSwitch3()
{
    uint8_t i,j;
    State[Index]=RawKeyPressed();
    ++Index;
    j=0xff;
    for(i=0; i<MAX_CHECKS;i++) j=j & State[i];
    Debounced State= j;
    if(Index>=MAX_CHECKS) Index=0;
}
```

*Listing 3: Code that debounces many switches at the same time*

A short loop ANDs all column entries of the array. The resulting byte has a one in each bit position where that particular switch was on for every entry in `State`. After the loop completes, variable `j` contains 8 debounced switch values.

One could exclusive OR this with the last `Debounced_State` to get a one in each bit where the corresponding switch has changed from a zero to a one, in a nice debounced fashion.

Don't forget to initialize `State` and `Index` to zero.

I prefer a less computationally-intensive alternative that splits `DebounceSwitch()` into two routines; one, driven by the timer tick, merely accumulates data into array `State`. Another function, `Whats_Da_Switches_Now()` ANDs and XORs as described, but only when the system needs to know the switches' status.

### Summing up

All of these algorithms assume a timer or other periodic call that invokes the debouncer. For quick response and relatively low computational overhead I prefer a tick rate of a handful of milliseconds. One to five msec is ideal. Most switches seem to exhibit under 10 msec bounce rates. Coupled with my observation that a 50 msec response seems instantaneous, it seems reasonable to pick a debounce period in the 20 to 50 msec range.

Hundreds of other debouncing algorithms exist. These are just a few of my favorite, offering great response, simple implementation, a no reliance on magic numbers or other sorts of high-tech incantations.

Thanks to many, many people who contributed suggestions and algorithms. I shamelessly stole ideas from many of you, especially Scott Rosenthal, Simon Large, Jack Marshall and Jack Bonn.