



(19) **United States**

(12) **Patent Application Publication**
TAYLOR

(10) **Pub. No.: US 2007/0226497 A1**

(43) **Pub. Date: Sep. 27, 2007**

(54) **COMMUNICATION PROTOCOL FOR
DEVICE AUTHENTICATION**

G06K 9/00 (2006.01)
G06F 17/30 (2006.01)
G06F 7/04 (2006.01)

(76) Inventor: **John P. TAYLOR**, San Diego, CA
(US)

(52) **U.S. Cl.** **713/168; 726/2; 713/169**

(57) **ABSTRACT**

Correspondence Address:
KYOCERA WIRELESS CORP.
P.O. BOX 928289
SAN DIEGO, CA 92192-8289

A communication protocol between a master device, such as a mobile phone, and a peripheral device facilitates authentication of the peripheral device. When a peripheral device is detected, the master device initiates a wake-up command to the peripheral device, transmits an authentication request command followed by challenge data to the peripheral device, and awaits responses from the peripheral device. The accessory receives the challenge data, performs a hash function on the challenge data, and generates response data. An authentication response type byte is sent to the handset followed by the response data. The handset compares the response data to pre-stored data that is associated with the challenge data. A match indicates that the accessory is authentic. The challenge/response data, also referred to as a plaintext/cyphertext pair, is pre-generated external to the handset using the hash function, then pre-stored in the handset.

(21) Appl. No.: **11/682,840**

(22) Filed: **Mar. 6, 2007**

Related U.S. Application Data

(60) Provisional application No. 60/786,164, filed on Mar. 27, 2006.

Publication Classification

(51) **Int. Cl.**
H04L 9/32 (2006.01)
H04L 9/00 (2006.01)

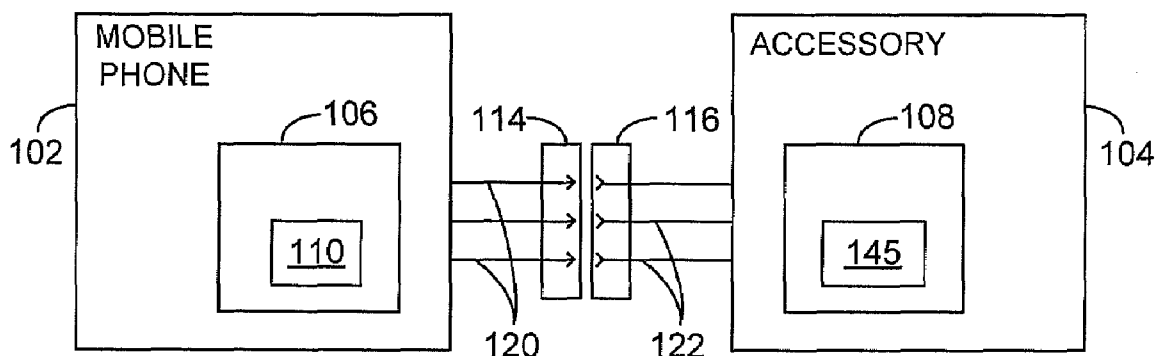

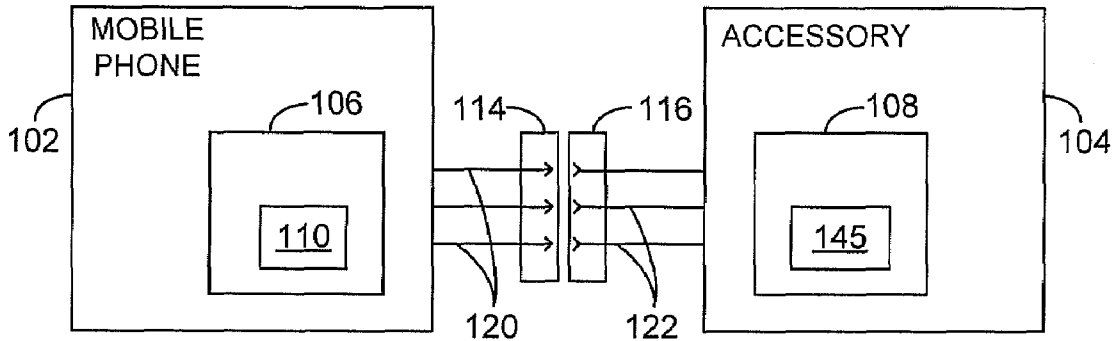

FIG. 1

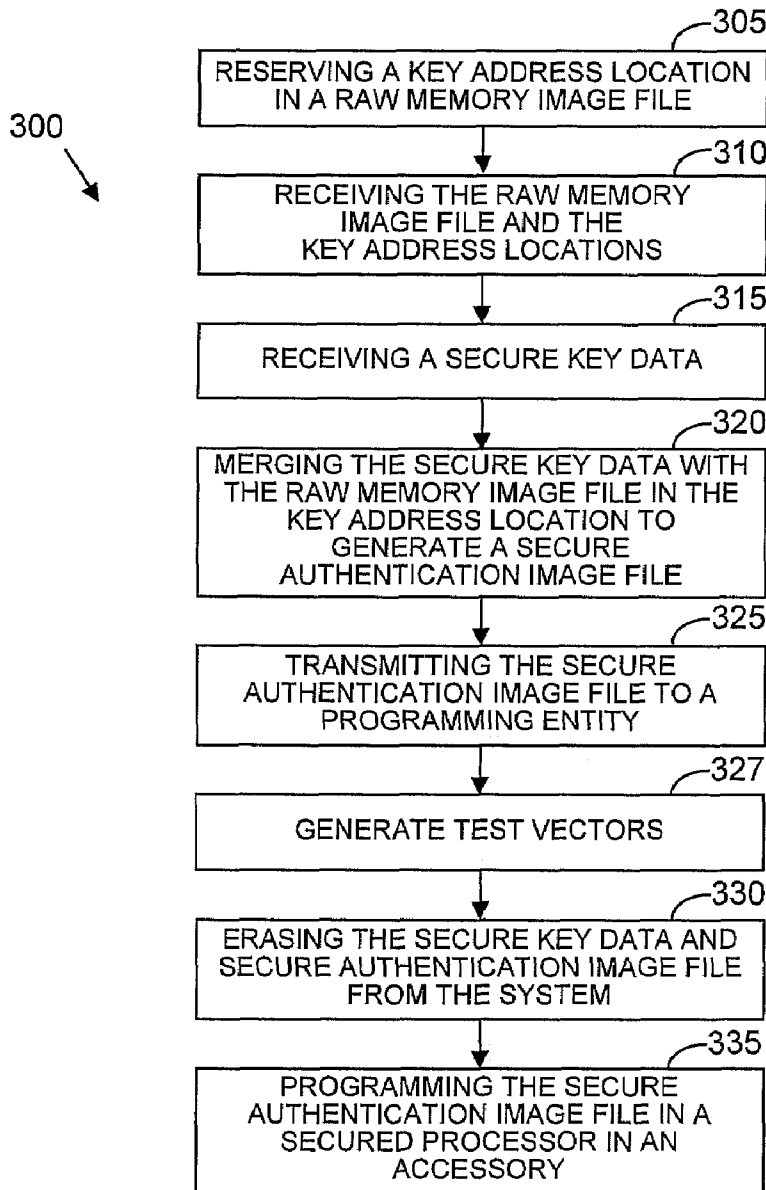

FIG. 3

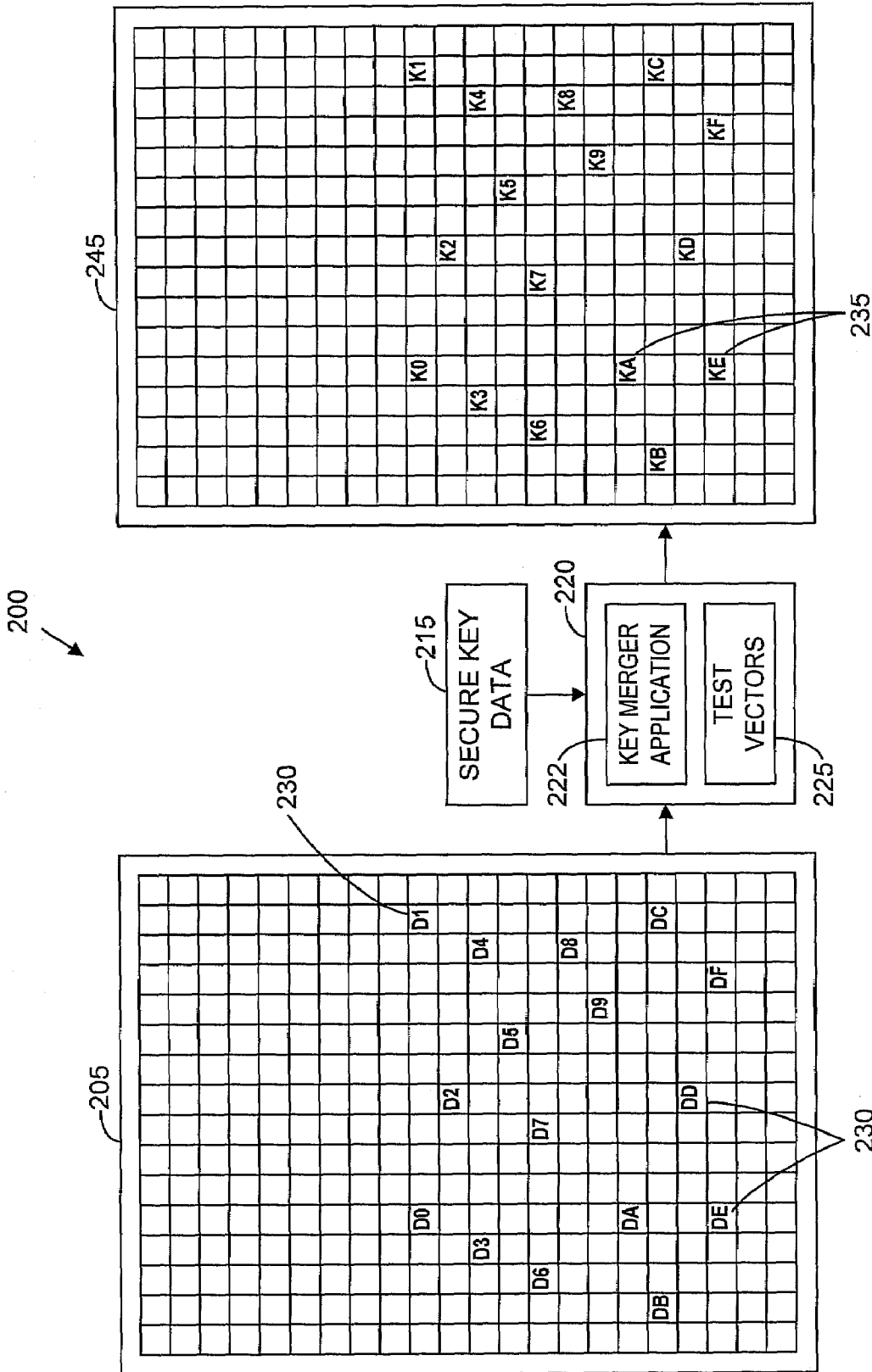

FIG. 2

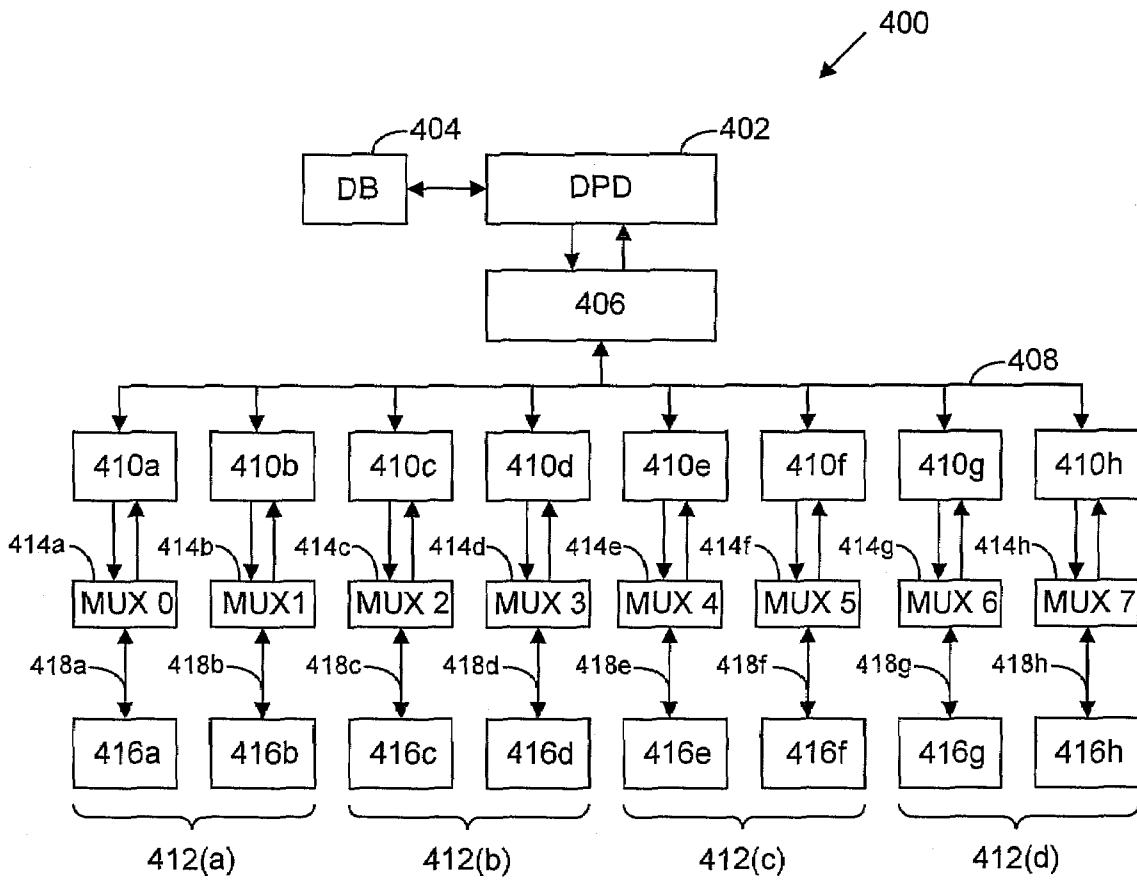

Fig. 4

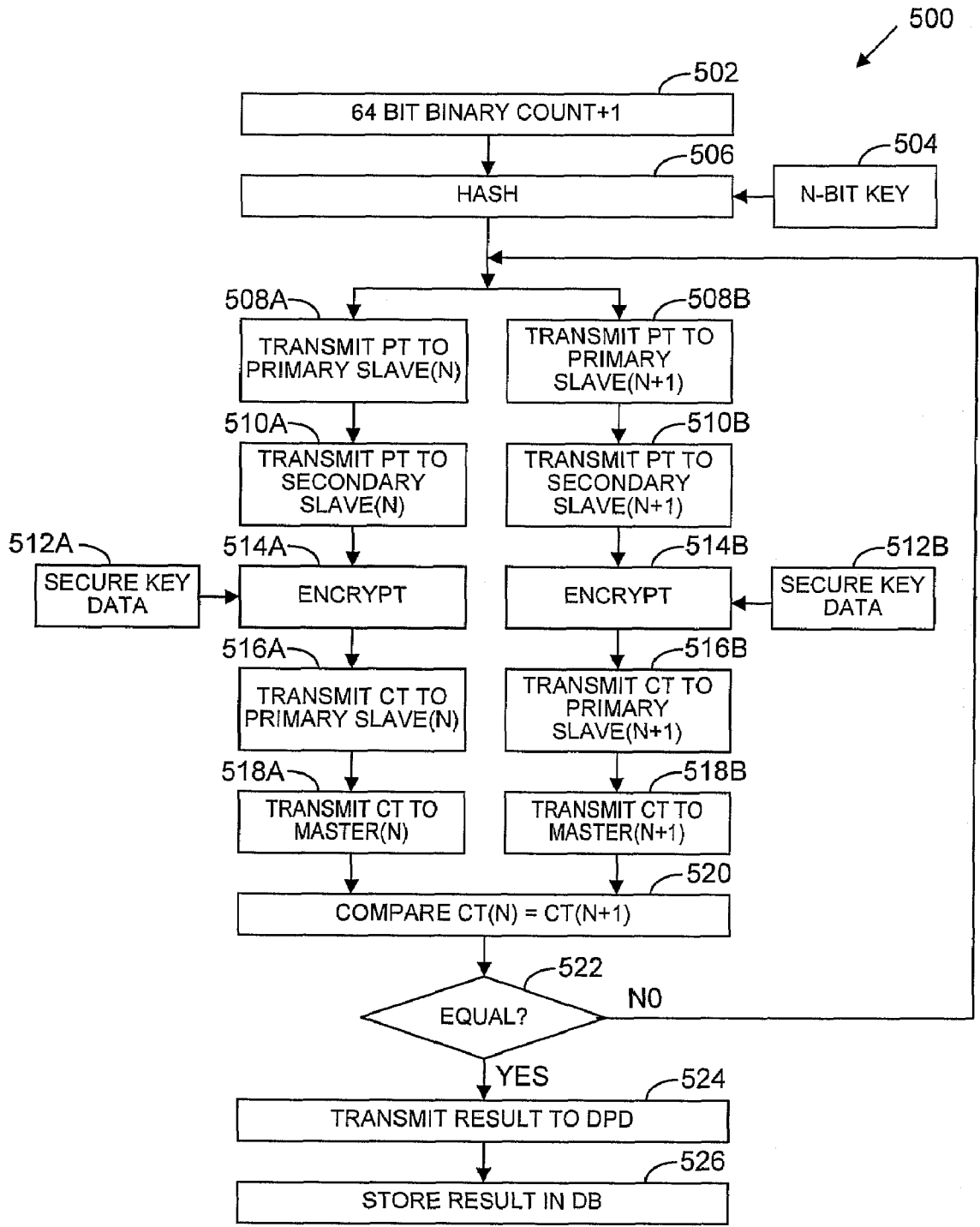

FIG. 5

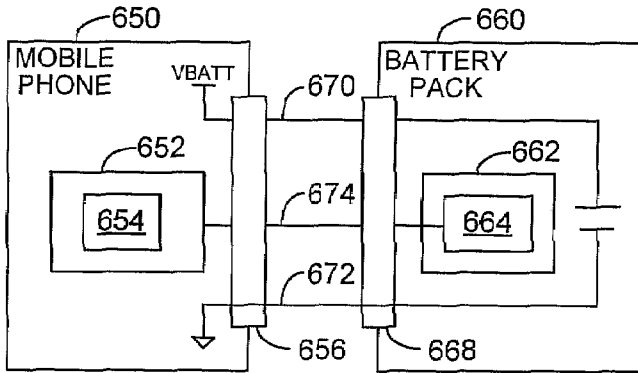

FIG. 6

608		626	
ACHIP OUT	UART TX	ID	UART RX
HI-Z	L	H	L
HI-Z	H	L	H
L	X	L	H
H	X	H	L

Fig. 7b

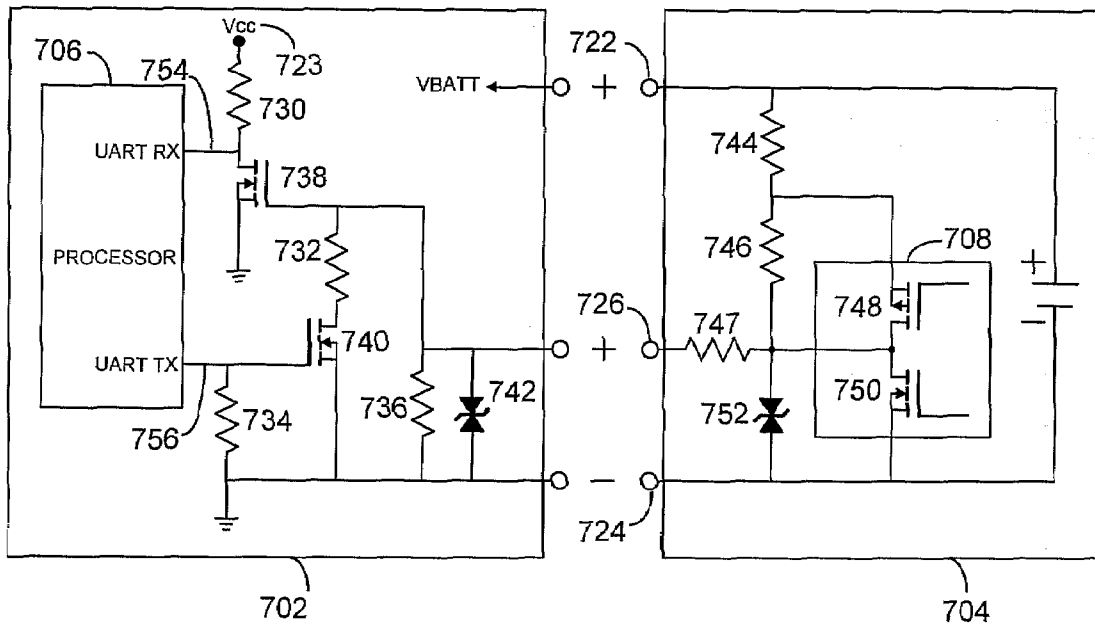

Fig. 7a

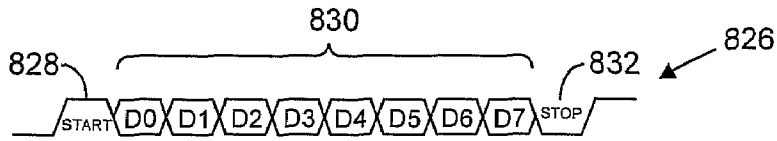

Fig. 8

900

BYTES SENT BY HANDSET	BYTES SENT BY PACK	BYTES ON ID PIN
0xff		0xff (WAKE UP)
0x00		0x00 (TIMING COMMAND)
	0x80	0x80 (TIMING RESPONSE)
	0xC3	0xC3 (TIMING BYTE)

902 (points to 0x00)
904 (points to 0x80)
906 (points to 0xC3)

Fig. 9

1100

BYTES SENT BY HANDSET	BYTES SENT BY PACK	BYTES ON ID PIN
0xff		0xff (WAKE UP)
0x01		0x01 (TEMP COMMAND)
	0x81	0x81 (TEMP RESPONSE)
	0xXX	0xXX (TEMP DATA)

1102 (points to 0x01)
1104 (points to 0x81)
1106 (points to 0xXX)

Fig. 11

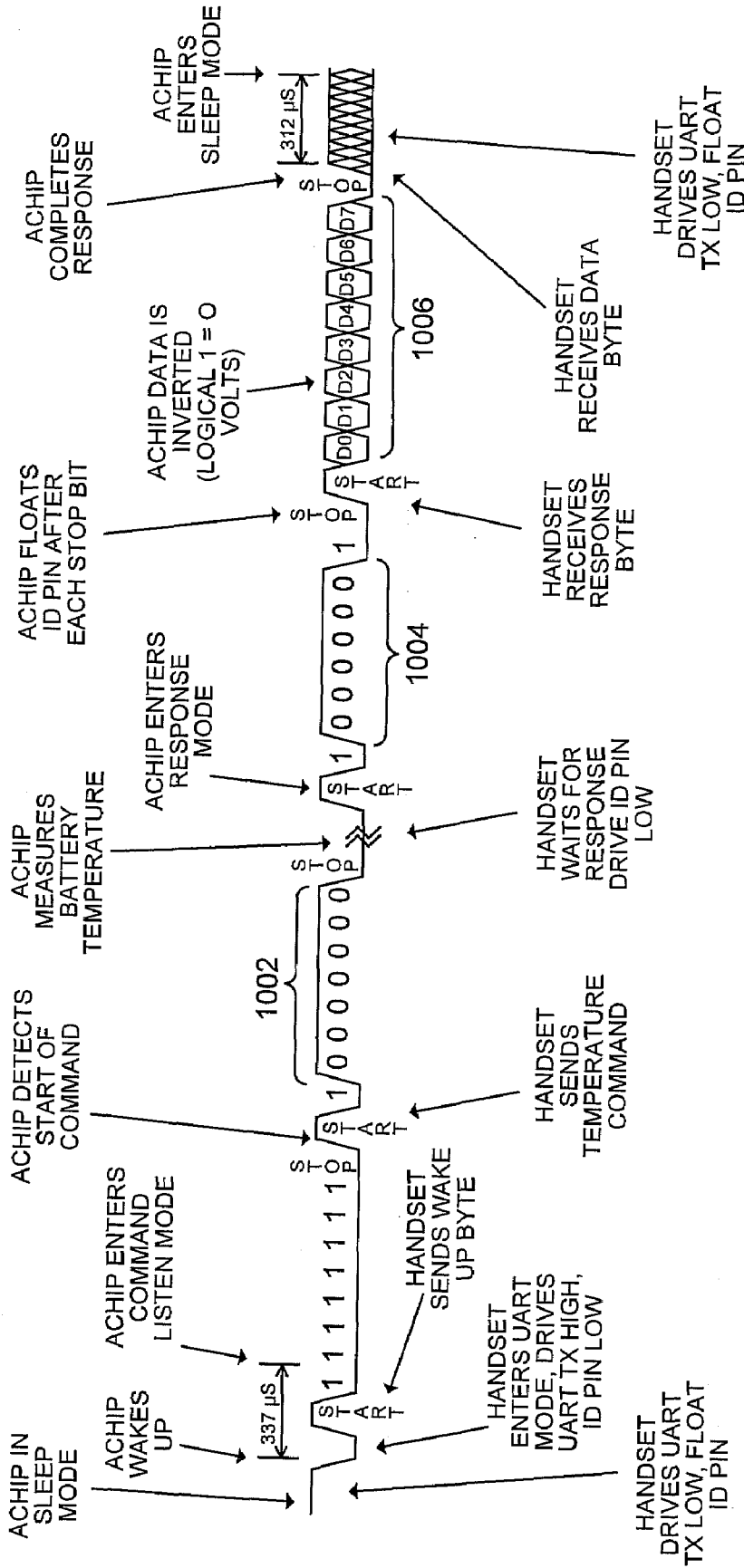

Fig. 10

1200

BYTES SENT BY HANDSET	BYTES SENT BY PACK	BYTES ON ID PIN
0xff		0xff (WAKE UP)
0x02		0x02 (ID/ VERSION COMMAND)
	0x82	0x82 (ID/ VERSION RESPONSE)
	0xXX	0xXX (VERSION DATA)

1202

1204 1206

Fig. 12

1300

BYTES SENT BY HANDSET	BYTES SENT BY PACK	BYTES ON ID PIN
0xff		0xff (WAKE UP)
0x04		0x04 (CHIP ID COMMAND)
	0x84	0x84 (CHIP ID RESPONSE)
	0xXX	0xXX (CHIP ID DATA MSB)
	0xXX	0xXX (CHIP ID DATA)
	0xXX	0xXX (CHIP ID DATA)
	0xXX	0xXX (CHIP ID DATA LSB)

1302

1304

1306

1308

1310

1312

Fig. 13

1400
↙

	BYTES SENT BY HANDSET	BYTES SENT BY PACK	BYTES ON ID PIN
1401	0xff		0xff (WAKE UP)
1402	0x08		0x04 (AUTHENTICATE COMMAND)
1404	0xXX		0xXX (CHALLENGE DATA MSB)
1406	0xXX		0xXX (CHALLENGE DATA)
	0xXX		0xXX (CHALLENGE DATA)
	0xXX		0xXX (CHALLENGE DATA)
	0xXX		0xXX (CHALLENGE DATA)
	0xXX		0xXX (CHALLENGE DATA)
	0xXX		0xXX (CHALLENGE DATA)
1408	0xXX		0xXX (CHALLENGE DATA LSB)
1410		0x88	0x88 (AUTHENTICATE RESPONSE)
1412		0xXX	0xXX (RESPONSE DATA MSB)
1414		0xXX	0xXX (RESPONSE DATA)
		0xXX	0xXX (RESPONSE DATA)
		0xXX	0xXX (RESPONSE DATA)
		0xXX	0xXX (RESPONSE DATA)
		0xXX	0xXX (RESPONSE DATA)
		0xXX	0xXX (RESPONSE DATA)
1416		0xXX	0xXX (RESPONSE DATA LSB)

Fig. 14

**COMMUNICATION PROTOCOL FOR
DEVICE AUTHENTICATION**

RELATED APPLICATIONS

[0001] This application claims the benefit of U.S. Provisional Application 60/786,164, filed Mar. 27, 2006, which is hereby incorporated by reference.

TECHNICAL FIELD

[0002] The present invention relates to the field of wireless communication devices. More specifically, the invention relates to authenticating peripheral devices attachable to the wireless communication devices.

BACKGROUND

[0003] Various peripheral devices, generally referred herein to as “accessories,” may be attached and detached from mobile phones, also referred to herein as “handsets”, and other wireless communication devices. These accessories, when attached, provide additional functionality and/or otherwise enhance the performance of the mobile phones. In other cases, accessories facilitate the user’s ability to productively or comfortably use the mobile phones. A phone battery, though normally thought of as integral with a phone, is also considered an “accessory” for purposes of the present disclosure.

[0004] During the design and development of wireless communication devices, it is common to test the compatibility and/or reliability of accessories anticipated for use with the wireless communication device. Such testing ensures that an accessory will operate with a reasonable level of compatibility with the wireless communication device. Unfortunately, accessories made available by third parties for use with wireless communication devices are often not tested or, even if tested, fall below the standards defined by manufacturers of wireless communication devices and/or other standards, e.g., defined by government bodies. Such accessories (referred to herein as “unauthorized accessories”) have the capability of damaging the wireless communication device and/or pose a safety threat to a consumer.

[0005] Existing techniques for preventing unauthorized accessories to be employed with wireless communication devices have been relatively easy to circumvent. For example, connectors employing unique mechanical keying arrangements can be overcome with mechanical modifications to the connectors. Electrical arrangements employing resistors for authentication are likewise easily circumvented with appropriate circuitry. Finally, digital communication techniques employing fixed passwords or rolling codes are relatively easy to defeat or mimic.

[0006] Accordingly, there remains a strong need in the art for an effective and secure authentication method and apparatus for wireless communication devices.

SUMMARY

[0007] An exemplary method of managing communications between a master device and an peripheral (accessory) device is disclosed. The peripheral device is connected to the master device by a connection port. The connection port includes include a communication terminal with one or more communications lines. The master device monitors the communication terminal for connection of the peripheral device.

If the peripheral device is detected, the master device initiates a wake-up command to the peripheral device, transmits an information request command to the peripheral device and awaits a response(s) from the peripheral device. An authentic peripheral device will return a response-type byte to indicate the type of response, followed by one or more bytes of the data requested in the information request command.

[0008] In one embodiment, the information request command is an authentication request command followed by challenge data. The peripheral device receives the challenge data, performs a hash function on the challenge data, and sends the master device an authentication response-type byte followed by response data. The hash function in one embodiment is an execution of a secure authentication application embodied in a secure authentication image file stored within the peripheral device. The master device, e.g., a wireless handset, receives the authentication response-type byte from the accessory followed by the response data. The handset compares the response data to pre-stored data that is associated with the challenge data. A match indicates that the accessory is authentic. The challenge data/response data, also referred to as plaintext/cyphertext pairs, is pre-generated external to the handset and then stored in the handset to ensure that a hash/encryption key has limited availability.

[0009] In an exemplary embodiment, the plaintext/cyphertext pairs are generated by supplying identical plaintext strings to two separate processors having an identical secure image file. The two processors execute the secure authentication application on the plaintext strings, and output cyphertext strings. If the cyphertext strings from the two separate processors match, then the plaintext/cyphertext pair is stored in a database. This process is repeated for any number of unique plaintext strings. Each generated unique plaintext/cyphertext pair will be used in master devices, such as a mobile phones, to verify that attached accessories are authentic as discussed above.

[0010] The secure image file utilized in the authentication of accessories is generated by supplying a secure key and a raw image file to a key merger application. The resulting merged file is the secure authentication image file. The secure key is safeguarded, by for example storing a single copy of the secure key and erasing the raw image file and secure key from the generating device. The secure authentication image file is then copied as needed for use in generating the plaintext/cyphertext pairs, and for including in manufactured accessories. However, since the secure key and raw image file are no longer available, the secure authentication image file utilized to authenticate devices will be difficult to counterfeit.

BRIEF DESCRIPTION OF THE DRAWINGS

[0011] The described embodiments are to be considered in all respects as illustrative and not restrictive. It should also be understood that the invention is not limited to the particular embodiments illustrated and described herein, but is capable of many rearrangements, modifications, and substitutions without departing from the scope of the invention. As such, the details of the present invention, both as to its structure and operation, may be gleaned in part by study of the accompanying drawings described below, in which like reference numerals refer to like parts.

[0012] FIG. 1 illustrates an exemplary arrangement including a mobile phone and a mobile phone accessory according to one embodiment of the invention.

[0013] FIG. 2 illustrates an exemplary system for generating secure authentication image files according to one embodiment of the invention.

[0014] FIG. 3 illustrates a flow chart for generating secure authentication image files according to one embodiment of the invention.

[0015] FIG. 4 illustrates an exemplary system for generating a database of plaintext/cyphertext key pairs according to one embodiment of the invention.

[0016] FIG. 5 illustrates a flow chart for generating a database of plaintext/cyphertext key pairs according to one embodiment of the invention.

[0017] FIG. 6 illustrates a mobile device and a battery pack accessory in a master-slave configuration according to one embodiment of the invention.

[0018] FIG. 7a illustrates an exemplary circuit for interfacing a handset and an accessory according to one embodiment of the invention.

[0019] FIG. 7b is an exemplary truth table defining the configuration of the communication terminal of FIG. 7 according to one embodiment of the invention.

[0020] FIG. 8 is an exemplary message format according to one embodiment of the invention.

[0021] FIG. 9 is an exemplary table which defines message commands for timing calibration according to one embodiment of the invention.

[0022] FIG. 10 is an exemplary detailed temperature communication transaction according to one embodiment of the invention.

[0023] FIG. 11 is an exemplary table which defines message commands for exchanging temperature information according to one embodiment of the invention.

[0024] FIG. 12 is an exemplary table which defines message commands for exchanging ID/Version information according to one embodiment of the invention.

[0025] FIG. 13 is an exemplary table which defines message commands for exchanging chip identification information according to one embodiment of the invention.

[0026] FIG. 14 is an exemplary table which defines message commands for exchanging authentication information according to one embodiment of the invention.

DETAILED DESCRIPTION

[0027] Referring first to FIG. 1, there is shown mobile phone 102 and mobile phone accessory 104 capable of being connected to mobile phone 102 according to one embodiment of the invention. Mobile phone 102 may be any wireless communication device capable of transmitting and receiving electromagnetic ("EM") energy in the radio frequency ("RF") band via an antenna coupled to the transceiver (not shown). Although the exemplary authentication method described herein is carried out by a mobile phone device for authenticating a mobile phone accessory, the method can also be used to authenticate battery packs or accessories for video cameras, notebook computers, MP3 players, and other electronic devices.

[0028] Mobile phone 102 typically includes a processor 106 for carrying out a number of functions related to operating mobile phone 102. The processor is coupled to a transceiver for communicating RF signals via the antenna (not shown). A power supply, such as a battery, supplies

power to the processor, memory, transceiver, and other mobile phone 102 components. Mobile phone 102 further includes a number of input/output ("I/O") devices (not shown) for receiving and transmitting information to the user.

[0029] Continuing with FIG. 1, mobile phone 102 further includes one or more accessory interfaces 114 for connecting an accessory, also referred to herein as a peripheral device, to the mobile phone 102. Although the techniques described herein may be used with a wide variety of accessories and accessory interfaces, FIG. 1 illustrates an example arrangement involving a battery accessory 104 having an interface 116 connected to accessory interface 114 of mobile phone 102. As shown in FIG. 1, accessory interface 114 of mobile phone 102 includes a plurality of lines 120, and interface 116 of accessory 104 includes a corresponding plurality of lines 122. By way of illustration, when mobile phone 102 and accessory 104 are connected, a first line of the plurality of lines 122 may be used to provide a supply voltage, a second line may be used to provide a reference voltage, e.g., such as ground, and a third line may be used to provide bi-directional communication between mobile phone 102 and accessory 104. The number of lines 120, 122 shown in FIG. 1 are for illustration purposes, only. Other embodiments may have one or any number of lines required for a particular peripheral accessory.

[0030] According to another embodiment, communication as described herein may be carried out over supply voltage lines. For example, bi-directional signaling may be employed over the voltage supply line via modulation. As another example, bi-directional signaling may be employed over the voltage supply line by employing switches to enable the line to operate in a first bi-directional signaling mode during the authentication process, and to enable lines the voltage supply line operate in a second voltage supplying mode after accessory 104 is authenticated. A benefit of enabling communication over existing voltage supply lines is that dedicated communication lines are not required, and thus, the interface and connectors between the mobile phone 102 and accessory 104 need not be modified from previous arrangements that do not employ the authentication method described herein.

[0031] Continuing with FIG. 1, processor 106 of mobile phone 102 is connected to accessory interface 114, and processor 108 of accessory 104 is connected to interface 116. Processor 106 may be the main processor of mobile phone 102 or may be an auxiliary processor within mobile phone 102. Processor 106 executes an authentication algorithm 110, and processor 108 executes a secure authentication application embodied in a secure authentication image file 145 stored therein. Processor 108 includes security features that prevents reading of any internal code including secure authentication image file 145. The contents and the generation of secure authentication image file 145 will be described in further detail below.

Generating Secured Authentication Image Files

[0032] Referring to FIG. 2, there is shown an exemplary system 200 for generating secure authentication image file 245. Generally, the secure authentication image file 245 corresponds with the secure authentication image file 145 of FIG. 1, and provides the programming executed by the processor 108 for authenticating accessory 104, among other things. An exemplary method for generating secure authen-

tication image file **245** according to one embodiment is depicted in flow chart **300** of FIG. **3**.

[0033] Certain details and features have been left out of flow chart **300** of FIG. **3** that are apparent to a person of ordinary skill in the art. For example, a step may consist of one or more sub-steps or may involve specialized equipment or materials, as known in the art. While steps **305** through **335** shown in flow chart **300** are sufficient to describe one embodiment of the present invention, other embodiments of the invention may utilize steps different from those shown in flow chart **300**.

[0034] At block **305**, a key address location(s) is reserved in a raw memory image file of system **200**. For example, in FIG. **2**, a plurality of key address locations (identified as DO through DF) **230** are reserved in a raw memory image file **205**. The raw memory image file **205** may include programming for a secured device such as battery accessory **104** of FIG. **1** where the reserved key address locations **230** may contain “dummy” or test data which will be replaced with secure key data during a subsequent secure merging procedure. Address reservation can be performed during the compilation and/or generation of programming instructions. Programming instructions in raw image file **205** may include an authentication program including an encryption algorithm such as a hash function for authenticating accessory **104** as described below.

[0035] In the illustrative embodiment shown in FIG. **2**, the key address locations **230** are shown distributed across a number of non-contiguous address locations. However, in other embodiments, other arrangements may be employed.

[0036] At block **310**, a data processing device **220** receives the raw memory image file **205** in a working memory **225** including the identification of the key address locations **230**. At block **315**, processor **220** receives a secure key data **215** in the working memory **225**. For example, the secure key data **215** may be 16 bytes (128 bits) and be a randomly generated value. To prevent public scrutiny of the encryption techniques, and more particularly, the encryption key, the access to the secure key data **215** should be limited.

[0037] At block **320**, a key merger application **222** executed by data processing device **220** merges the secure key data **215** with the raw image memory file **205** in the key address location **230** to generate a secured authentication image file **245**. The size of the reserved key address locations **230** is sufficient to store the secure key data **215**. The resulting secure authentication image file **245** contains the secure key data **215** in the secured key address locations **235**.

[0038] At block **325**, secure authentication image file **245** is transmitted to a programming entity which will program secure authentication image file **245** into integrated chips. In one example, the programming entity is a processor integrated circuit (PIC) manufacturer that supplies PICs, for example, processor **108**, for use in accessories **104**, as shown in FIG. **1**. The programming entity can integrate secure authentication image file **245** into the PIC as shown in step **335**.

[0039] At step **327**, a set of test vectors **225** are generated for future use to verify manufactured devices, e.g., the PICs, containing secure authentication image file **145**, **245**. Test vectors **225** include a limited set of plain text strings and cyphertext strings. The cyphertext strings are generated

from an encryption algorithm, utilizing secure authentication image file **245**, that is applied to the limited set of plain text strings.

[0040] At step **330**, secured key data **215** and secure authentication image file **245** are erased/deleted from system **200**. As discussed above at step **335**, secure authentication image file **245** is programmed into a secured processor, such as processor **108** of FIG. **1**. Secured processors, as used in the present application, prevent the reading of its internal code such as the secure authentication image file. For example, in factory programmed PICs, the bits that enable the security features are spread across the memory array and can only be cleared by mass erasing of the memory device. Additional security features that prevent the reading of the internal code may also be employed as additional security measures.

Generation of a Plaintext/Cyphertext Database

[0041] Referring now to FIG. **4**, there is shown system **400** for generating database **404** of plaintext/cyphertext key pairs, also referred to as vectors, according to one embodiment of the invention. The plaintext/cyphertext pairs are generated for use in each manufactured device such as the mobile phone **102** shown in FIG. **1**. Thus a suitable system, such as the system described herein, must be employed to generate the required volume of plaintext/cyphertext pairs. The operation of system **400** according to one embodiment will be discussed with reference to flow chart **500** of FIG. **5**. Certain details and features have been left out of flow chart **500** of FIG. **5** that are apparent to a person of ordinary skill in the art. For example, a step may consist of one or more sub-steps or may involve specialized equipment or materials, as known in the art. While steps **502** through **526** shown in flow chart **500** are sufficient to describe one embodiment of the present invention, other embodiments of the invention may utilize steps different from those shown in flow chart **500**.

[0042] System **400** includes data processing device (DPD) **402** connected to a plurality of slave processors **416a-h**. Each slave processor **416a-h** stores and executes a secure authentication image file, as discussed above. The secure key data is included as part of the secure authentication image file. It is noted, each slave processor **416a-h** mimics the operation of the accessory device to be authenticated in use in that each slave processor **416a-h** receives a plaintext challenge and responds with a cyphertext response.

[0043] In the particular embodiment shown in FIG. **4**, master processor **406** is connected to a high speed interface **408** to eight primary slave processors **410a-h**. The master processor **406** is also connected to data processing device **402** in order to communicate the vectors to data processing device **402** for storage in the database **404**. Each of primary slave processors **410a-h** is connected to a corresponding secondary slave processor **416a-h** which communicate through a secondary slave interface **418a-h**. Interface **408** operates at least eight times the speed of the primary to secondary slave interface **418a-h** in this particular arrangement to provide efficiency in parallel processing as discussed further below.

[0044] Master processor **406** uses a counter, depicted as counter function **502** of FIG. **5**, that can be set to a specific value before being commanded to start the database generation. This configuration allows multiple master processors to work on ranges of vectors, thereby allowing multiple

units to work toward a contiguous database at a speed set by their numbers. In one embodiment the counter function **502** utilizes a 64 bit binary count.

[0045] At block **506**, master processor **406** executes a hash function with a key, such as a 128 bit key supplied at block **504**, and a counter value for generating a plaintext (PT) string. At blocks **508a,b** of FIG. **5**, this plaintext string, also referred to as a challenge, is communicated to a primary slave processor, for example **410a**. At blocks **510a,b**, this primary slave processor then communicates the plaintext string to a secondary slave processor, for example **416a**, via multiplexor (MUX) **414a-h**. At block **514a** and **514b**, the secondary slave processor, for example **416a**, encrypts the plaintext into a cyphertext (CT) response using the secure key data provided at blocks **512a** and **512b**, respectively. At blocks **516a**, **516b**, **518a** and **518b**, the cyphertext response is then communicated back to master processor **406** by way of primary processor **410a**.

[0046] In system arrangement **400**, primary slave processors **410a-h** and secondary slave processors **416a-h** are arranged into four, two-device groups **412a-d**. Each group **412a-d** comprises a cyphertext vector generating device and cyphertext vector verifying device to process a plaintext string. For example, group **412** includes cyphertext generating device (collectively, primary slave processor **410a** and secondary slave processor **416a**) and cyphertext verifying device (collectively, primary slave processor **410b** and secondary slave processor **416b**). Blocks **508a-518a** of FIG. **5** may correspond to the operation of the cyphertext vector-generating device, and blocks **508b-518b** may correspond to the operation of the cyphertext vector verifying device.

[0047] At block **520**, the cyphertext string generated by the cyphertext vector generating device is compared to the cyphertext string generated by the cyphertext vector verifying device. At decision block **522**, a determination is made if the cyphertext responses generated by the cyphertext generating device and cyphertext verifying device of the particular group match. If a match is determined, then in step **524** the plaintext and cyphertext are transmitted to data processing device **402** and stored as a vector in database **404**, at step **526**, for later distribution to production devices, such as mobile phone **102** as shown in FIG. **1**. Step **502** is repeated to increment the counter value, as shown in FIG. **5**, and the process repeats for a next plaintext string. A benefit of using a consecutive binary count in conjunction with a bidirectional hashing algorithm is that duplicate vectors are avoided.

[0048] If the cyphertext responses do not match, at decision block **522**, the same plaintext is resent to the group, for example **412a**, until a matching response is obtained. A mismatch can occur due to device errors such as power glitches and line noise, for example. This verification step is advantageous to verify the cyphertext responses since the encryption algorithm and the encryption key are not available externally from the secondary slave processors **416a-h**. The verification step confirms that the values in the database will not result in an improper rejection of authentic accessory devices in the field.

[0049] In system arrangement **400**, four groups **412a-d** are implemented to increase efficiency in generating database **404**. However, in other embodiments, any arrangement may be implemented in accordance with such factors as interface bandwidth considerations.

[0050] Interface **418a-h** is a low speed interface in one embodiment, such as 9.6 kbps. This arrangement provides a number of advantages, including reduced power requirements and a sufficiently slow interface that renders reverse engineering the secure authentication image file stored in the secondary slave processor impractical. The slow interface is compensated for using the parallel processing technique described above. Thus, a system and method for securely generating the plaintext/cyphertext pairs has been disclosed.

Bi-Direction Interface for Authenticating Accessories

[0051] Bi-directional interfaces that may be used for accessory authentication will be described with reference to FIGS. **6**, **7a** and **7b**. In the examples that follow, a battery pack accessory for use in a mobile phone is illustrated, although the accessory authentication may also be used with other accessory types for various devices as discussed above.

[0052] As shown in an exemplary embodiment of FIG. **6**, the peripheral device is a battery pack connected to a mobile phone via connectors **656**, **668**. As discussed above with reference to FIG. **1**, one or more signal lines **670**, **672**, **674** connect mobile phone **650** and battery pack **660**. In an exemplary embodiment, the master device, that is, the mobile phone **650**, communicates with the peripheral device, that is, the battery pack **660**, using a half duplex communication. Half duplex communication typically describes transmission of data one way at a time in a bi-directional communication line(s). The communication between the battery pack and the mobile phone utilizes a two to one data line connection, a one to one data line connection, or any other suitable data or signal line connection, as discussed above with reference to FIG. **1**. As illustrated in FIG. **6**, connectors **656**, **668** also supply a battery voltage, vbatt, and a ground on lines **670** and **672** respectively.

[0053] Processor **652** of the mobile phone **650**, contains plaintext/cyphertext pairs and a communication algorithm **654**. A plaintext challenge, as discussed in detail below, is sent over signal line **674** from processor **652** to processor **662** of the battery pack **600**. Processor **662** performs a hash algorithm on the plaintext challenge utilizing the secure authentication file **664**, and returns a response cyphertext string. If the response cyphertext string matches the cyphertext string pre-stored in the mobile phone, then the battery pack is an authentic battery pack **660**.

[0054] Referring to FIG. **7a**, a first embodiment of battery pack **704** is shown connected to an embodiment of a handset **702**. This illustrated embodiment utilizes a UART for a two signal line to one signal line half duplex communication between the handset **702** and the battery pack **704**. However, as discussed above, there are many combinations of signal line communications that may be used to realize the accessory authentication discussed herein.

[0055] Continuing with FIG. **7a**, handset **702** includes processor **706** with ports UART RX **754** and UART TX **756**. Battery pack **704** has three terminals including battery voltage (Vbatt) terminal **722**, ground terminal **724**, and communication terminal **726**. Vbatt **722** and ground terminal **724**, in one embodiment, may be positive and negative connections to battery pack **704**. Vbatt **722** is connected to a power supply circuit (not shown) that provides a supply voltage (Vcc) to Vcc terminal **723**. Communication terminal **726** provides a communication connection to authentication

chip 708, also referred to authentication processor 708. Communication terminal 726 also may be referred to as an identification (ID) terminal. Authentication chip 708 can provide such functions as an accurate measurement of battery temperature, information about battery pack 704 representing pack capacity, serial number, and the authentication function, for example. In one embodiment, communication may be carried out at 9600 baud over the communication terminal 726 in a half-duplex, 8 data bit, 1 start-bit, 1 stop-bit, no-parity format.

[0056] Authentication chip 708 contains a secure authentication image file including an algorithm for encrypting (hashing or scrambling) data. Each handset 702 contains a set of unique challenge-response pairs (vectors or plaintext/cyphertext pairs) programmed during provisioning. To authenticate battery pack 704, handset 702 transmits a plaintext challenge over communication terminal 726 to battery pack 704. Authentication chip 708 executes the algorithm utilizing the plaintext challenge, hashes it, and returns a cyphertext response to handset 702. Handset 702 compares the cyphertext response to the corresponding cyphertext component of the challenge-response pair. If a match is determined, battery pack 704 is authenticated. If a match is not determined, battery pack 704 is considered counterfeit. Handset 702 may restrict use or operation of battery pack 704.

[0057] It is possible that vibration, electromagnetic interactions, power transients, etc., could corrupt the communication between handset 702 and battery pack 704. Therefore, handset 702 can be configured to make several attempts to authenticate battery pack 704 if the initial attempt fails. Vibration, contaminated electrical contacts, and high-level electrical noise and other spurious signals may cause unintended transitions to occur on communication terminal 726. These transitions will cause authentication chip 708 to wake up and possibly send a response to noise that it has interpreted as a command. Handset 702 may be programmed to accommodate and ignore these transmissions.

[0058] In the exemplary embodiment of FIG. 7, communication with authentication chip 708 in battery pack 704 takes place over a single bi-directional communication signal line connected to communication terminal 726 of battery pack 704. A standard 8-bit, no parity, single start-bit, single stop-bit serial data stream conveys all information. Handset 702 initiates all communication. Authentication chip 708 in battery pack 704 will only respond to properly formatted requests from handset 702. Battery pack 704 does not have the capability to enable or disable itself. As discussed above, handset 702 interrogates battery pack 704 to determine whether battery pack 704 is authentic.

[0059] The line connected through communication terminal 726 supports a bidirectional serial data link between authentication chip 708 and handset 702. Handset 702 can detect the presence of battery pack 704 by monitoring the open-circuit voltage of communication terminal 726. In one embodiment, pull-up resistor 744 is 300 ohms, pull-up resistor 746 is 33k ohms, resistor 747 is 330 ohms, resistor 736 is 1M ohms, and resistor 730 is 47k ohms. Resistor 734 may be 1M ohms and provides current limiting into and out of communication terminal 726. Resistor 732 may be 3.3k ohms and is a pull-up resistor that maintains the authentication circuit in a "sleep" state when the battery 704 is not connected to the handset 702. These resistor values are only

exemplary are selected to control communication via communication terminal 726 as discussed herein.

[0060] Communication terminal 726 in battery pack 704 has three possible states: idle/receive, TX high, TX low. When communication terminal 726 is in idle/receive state, i.e., it is not transmitting, transistors 748 and 750 will be off. In the idle mode, communication terminal 726 has a 33.66k ohm impedance to Vbatt terminal 722. When communication terminal 726 is in the TX high state, transistor 748 is on and transistor 750 is off, resulting in a 660 ohm impedance to Vbatt terminal 722 of battery pack 704. When communication terminal 726 is in the TX low state, transistor 748 is off and transistor 750 is on, resulting in a 330 ohm impedance to ground terminal 724.

[0061] Battery pack 704 may be able to control communications on communication terminal 726 under certain circumstances. This capability is enabled by selection of resistors 732, 746 and 747. The truth table depicted in FIG. 7b defines how the configuration of communication terminal 726 (ID 626) is controlled by authentication chip 708 (ACHIP OUT 608).

[0062] Referring back to FIG. 7, an example circuit for combining the handset's UART transmit and receive signals into a single signal communicated on communication terminal 726 is shown. Transistors 738 and 740 are N-channel CMOS logic-level switching transistors. Note that the UART receive (UART RX) and UART transmit (UART TX) signals are inverted by this circuit. There are three possible states for the UART TX signal: High, Low, and High-Z. When the UART TX signal is in the low state, or the high-Z state, transistor 740 is turned off. Communication terminal 726 will show a very high, e.g., one million ohm, impedance to ground terminal 724. If battery pack 704 is in the idle/receive (sleep) state, the voltage at communication terminal 726 will be close to the voltage level of Vbatt terminal 722 due to the pull-up resistor 746 in battery pack 704. Transistor 738 subsequently pulls the voltage at UART RX terminal 754 to ground. The circuitry shown in FIG. 7 consumes minimal power in sleep mode with communication terminal 726 pulled up to Vbatt.

[0063] When the UART TX signal is high, transistor 740 is on, connecting resistor 732 to ground. This configuration results in communication terminal 726 having an effective impedance of 3.3k ohms to ground. When connected to battery pack 704, assuming battery pack 704 is in idle/receive state, communication terminal 726 will be pulled down to approximately 0.1 of the voltage level of Vbatt terminal 722 which turns transistor 738 off and pulls up UART RX terminal 754 to a high state by resistor 730. All bits transmitted on UART TX terminal 756 will be received immediately at UART RX terminal 754, if authentication chip 708 is in high-Z or "receive" mode.

[0064] The handset software is capable of receiving both the data transmitted by handset 702 and the data transmitted by battery pack 704 on UART RX terminal 754. The UART TX terminal 756 should be in the low state or high-Z state when handset 702 is not transmitting data to battery pack 704. Handset circuit 702 will draw approximately 80 microamperes from Vcc 723 in this mode. When handset 702 is in sleep mode, less than 4 microamperes is drawn from battery pack 704.

[0065] Diodes 742 and 752 are electrostatic device (ESD) protection devices. Care should be taken to minimize the amount of capacitance that the ESD devices add to com-

munication terminal 726 circuit. The rise time of the signal transmitted by handset 702 to battery pack 704 is determined by the total pull-up impedance of resistors 744, 746, and 747 (33.66K) and the total capacitance on communication terminal 726. The ESD diode 747 in battery pack 704 has a maximum capacitance of 50 pF, for example. In an exemplary embodiment, the total capacitance on communication terminal 726 is less than 150 pF. Generally, the drain-source resistance of transistor 738, when turned on, is less than or equal to 50 ohms.

[0066] Processor 706 transmits binary zeros as a low-voltage output and binary ones as a high-voltage output from the UART TX pin 756. UART RX pin 754 expects this same signal level. The UART TX signal is inverted by transistor 740 to drive communication terminal 726. Inverted signaling is expected at communication terminal 726, i.e., a high level signal ($>0.85 \cdot V_{\text{batt}}$) representing a binary zero and a low-level signal ($<0.15 \cdot V_{\text{batt}}$) representing a binary one. The signal on communication terminal 726 is inverted by transistor 738 before being applied to UART RX pin 754. When the UART in handset 702 is driving UART TX pin 756, the idle state of UART TX pin 756 (when there is no data being sent by the UART) will be a logical one, i.e., a high voltage level. This will turn on transistor 740 and pull battery pack 704 ID pin low through 3.3k-ohm resistor 732. Battery pack 704 will still be able to drive communication terminal 726 high or low in this state by activating transistors 748 or 750.

[0067] When the authentication chip is driving communication terminal 726 to respond to a command, it actively drives the pin high and low using transistors 748 and 750 in FIG. 7. There is a period of approximately 300 microseconds following each stop bit during which transistors 748 and 750 are both off, floating communication terminal 726. To avoid corrupting received data communicated via floating communication terminal 726, handset 702 asserts UART TX during reception by driving a logical one on UART TX pin 756 to turn on transistor 740 and pull down communication terminal 726.

Communication Protocol for Authenticating Accessories

[0068] A communication protocol for authenticating accessories will be described with reference to FIGS. 6 and 8-14. Referring to FIGS. 6 and 8, there is shown an exemplary communication message format 826 communicated over communication terminal/line 674 according to one embodiment. Communication message 826 may be an 8-bit byte including single start bit 828, 8 data bits 830, and single stop bit 832.

[0069] In certain embodiments, authentication processor 662 is connected to battery pack 660 at the battery pack manufacturer and is powered at all times throughout the life of battery pack 660. In these cases, authentication processor 662 should use as little power as possible. Authentication processor 662 primarily operates in sleep mode to conserve power. During sleep mode authentication processor 662 is not executing instructions, it is only monitoring communication line 674 for transitions (high-to-low or low-to-high transitions). When a transition occurs on communication terminal 674, authentication processor 662 wakes up and begins operating. However, authentication processor 662 does not begin to process signals on communication line 674 until after the initial transition occurs, such as until 337.5

microseconds (25 microseconds plus three 9600-baud bit periods), for example. If no commands are received over communication terminal 674, authentication processor 662 returns to sleep mode (e.g., 2.3 seconds after waking up). If a command is received within an "awake" window (e.g., 2.3 seconds), authentication processor 662 processes the command and returns to sleep mode after transmitting the response to the command.

[0070] The wake-up period can be facilitated a number of ways. One method is to use a timer to determine when the initial transition (e.g., 337.5 microsecond period) has elapsed and then send the command byte(s). Another method is to immediately send the wakeup byte (0xff) during a first portion of the wakeup interval (e.g., 232 microseconds), followed by the command bytes. The wakeup byte will send one "zero" bit (the start bit) followed by nine "one" bits (the eight data bits plus the stop bit). Sending the wakeup byte creates sufficient delay to ensure that the first command byte is sent after the initial transition period (e.g., 337.5 microseconds).

[0071] All communication with battery pack 660 is initiated by handset 650 in the embodiment of FIG. 6. Discussed herein are command messages that handset 650 sends to battery pack 660 including a temperature command, an ID/version command, a chip ID command, and an authentication command. Each command begins by waking up battery pack 660 as mentioned above. Each of the commands includes a single command byte with the exception of the authentication command that sends an 8-byte challenge to battery pack 660 after the command byte. If more bytes are sent than expected by battery pack 660, they will either be ignored or will interfere with the response signals from battery pack 660.

[0072] In some cases, it may be desirable to calibrate the timing of device communication between handset 650 and battery pack 660. FIG. 9 illustrates Table 900 which identifies exemplary message commands communicated between handset 650 and battery pack 660 for timing calibration. Battery pack 660 responds to a timing command (0x00) 902 by sending a timing response (0x80) 904 followed by a timing byte (0xC3) 906. Handset 650 can measure the length of the string of four logical zeros in this timing byte 906, divide by four, and use the resulting value as the time for a single data bit during transmission or reception. The four logical zeros will be a high level signal in the center of the byte. The two bits on either end of the binary signal 904 are not used for timing purposes.

[0073] FIG. 10 depicts a diagram incorporating components of a temperature measurement transaction and FIG. 11 shows Table 1100 which identifies exemplary message commands communicated between handset 650 and battery pack 660 for exchanging temperature information. Handset 650 sends temperature command (0x01) 1002, 1102 to battery pack 660, and battery pack 660 responds by sending a temperature response byte (0x81) 1004, 1104 followed by a byte containing the temperature data 1006, 1106.

[0074] FIG. 12 shows Table 1200 which identifies exemplary message commands communicated between handset 650 and battery pack 660 for exchanging ID/Version information associated with battery pack 660. Handset 650 sends ID/Version command (0x02) 1202 to battery pack 660, and battery pack 660 responds by sending a ID/Version response byte (0x82) 1204 followed by a byte containing the ID/Version data 1206 associated with battery pack 660. The ID/Ver-

sion data may identify such information as battery pack manufacturer, battery pack version, battery pack serial number, battery pack lot, for example.

[0075] FIG. 13 shows Table 1300 which identifies exemplary message commands communicated between handset 650 and battery pack 660 for exchanging identification information associated with authentication chip 662. Handset 650 sends chip ID command (0x04) 1302 to battery pack 660, and battery pack 660 responds by sending a chip ID response (0x84) 1304 followed by chip ID information. For example, the chip ID information may comprise four bytes of messages including chip ID data most significant bit (MSB) 1306, chip ID data 1308, chip ID data 1310, and chip ID data least significant bit (LSB) 1312 as illustrated in FIG. 13.

[0076] FIG. 14 shows Table 1400 which identifies exemplary message commands communicated between handset 650 and battery pack 660 for exchanging authentication information for authenticating battery pack 660. To initiate a battery authentication, handset 650 sends a wakeup byte (0xff) 1401, followed by an authentication command (0x08) 1402, followed by a "challenge", such as a 64-bit (8-byte) challenge command. As shown in FIG. 14, the challenge command may include challenge data MSB 1404, followed by a challenge data payload 1406, followed by challenge data LSB 1408.

[0077] Battery pack 660 performs a hash function on the challenge to generate a "response", such as a 64-bit (8-byte) response. As discussed above, the challenge is typically unique to each handset. The response is transmitted back to handset 650 by sending an authentication response (0x88) 1410 followed by the response command. For example, the response command may include response data MSB 1412, followed by a response data payload 1414, followed by response data LSB 1416.

[0078] Handset 650 compares the received response 1412, 1414, 1416 with a stored response associated with the challenge 1404, 1406, 1408. If a match is determined the given challenge, then battery pack 660 is authenticated. If a match is not determined after several attempts to account for possible communication errors, battery pack 660 is considered counterfeit. Handset 650 may restrict use or operation of battery pack 660.

[0079] To maintain the secrecy of the operation of the hashing function in authentication chip 662, handset 650 does not contain a copy of the hashing algorithm as discussed above. Instead, at the time of software provisioning of handset 650, a challenge-response pair(s) is stored in the memory of handset 650. The techniques for generating challenge-response pairs is discussed above.

[0080] From the above description of exemplary embodiments of the invention, it is manifest that various techniques can be used for implementing the concepts of the present invention without departing from its scope. Moreover, while the invention has been described with specific reference to certain embodiments, a person of ordinary skill in the art would recognize that changes could be made in form and detail without departing from the spirit and the scope of the invention. For example, the specific layout arrangement of first radiator arm and second radiator arm of the multi-band antenna could be modified from that discussed above without departing from the scope of the invention. The described exemplary embodiments are to be considered in all respects as illustrative and not restrictive. It should also be under-

stood that the invention is not limited to the particular exemplary embodiments described herein, but is capable of many rearrangements, modifications, and substitutions without departing from the scope of the invention.

What is claimed is:

1. A method for a device to authenticate an accessory having at least one communication port connected to the device, the method comprising:

driving the at least one communication port to a first voltage level to maintain the accessory in a sleep mode; transitioning the at least one communication port to a second voltage level to initiate a wake up condition in the accessory;

transmitting a wake up command to the accessory via the at least one communication port;

transmitting an information request command via the at least one communication port to the accessory;

receiving an information request response via the at least one communication port from the accessory;

authenticating the accessory when at least a portion of the received information request response matches a pre-stored expected information request response.

2. The method of claim 1, wherein the information request command is an authentication command, and wherein the information request response is an authentication response-type byte from the accessory.

3. The method of claim 2, further comprising:

sending a plaintext challenge to the accessory.

4. The method of claim 3, further comprising:

receiving a cyphertext response from the accessory on the at least one communication port.

5. The method of claim 4 further comprising:

comparing the cyphertext response with a pre-stored cyphertext response associated with the plaintext challenge;

permitting use of the accessory if the cyphertext response matches the pre-stored cyphertext response; and

limiting use of the accessory if the cyphertext response does not match the pre-stored cyphertext response.

6. The method of claim 1, further comprising:

monitoring the at least one communication port;

detecting the accessory attached to the at least one communication port;

driving the at least one communication port to the first voltage level to maintain the accessory in a sleep mode.

7. The method of claim 3, further comprising:

monitoring the single communication port for a voltage level transition at the accessory;

detecting the voltage level transition at the accessory;

entering a command listen mode at the accessory;

detecting the wake up command at the accessory;

receiving the authentication command from the device;

receiving the plaintext challenge from the device;

performing a hash function on the received plaintext challenge utilizing a secure authentication image file to generate a cyphertext response;

sending an authentication response type byte to the handset; and

sending the generated cyphertext response to the handset.

8. The method of claim 1, wherein the information request command is a timing command, and wherein the information request response comprises a timing response and a timing byte.

9. The method of claim 1, wherein the information request command is a temperature command, and wherein the information request response comprises a temperature response and temperature data.

10. The method of claim 1, wherein the information request command is an identification command, and wherein the information request response comprises an identification response and identification data.

11. The method of claim 1, wherein the transmitting and the receiving steps between the device and the accessory are half duplex communications.

12. The method of claim 1, wherein the device is a wireless communication device, and the accessory is a battery.

13. A system for authenticating an accessory, comprising: a device comprising:

at least one communication port for connection to the accessory;

a memory for storing at least one information request command and at least one expected information request response; and

a processor coupled to the memory and the at least one communication port, the processor driving the at least one communication port to a first voltage level to maintain the accessory in a sleep mode, transitioning the at least one communication port to a second voltage level to initiate a wake up condition in the accessory, transmitting a wake up command to the accessory via the at least one communication port, transmitting the at least one information request command via the at least one communication port to the accessory, receiving an information request response via the at least one communication port from the accessory, and authenticating the accessory when at least a portion of the received information request response matches the at least one expected information request response; and

the accessory for attachment to the device through the at least one communication port, the accessory comprising:

a secure authentication image file; and

a accessory processor for detecting a voltage level transition, entering a command listen mode, detecting the wake up command, receiving the at least one information request command, generating an information request response, and transmitting the information request response to the device through the at least one communication port.

14. The system of claim 13, wherein the at least one information request command comprises an authentication command and a plaintext challenge;

wherein at least a portion of the information request response is a cyphertext response;

wherein the accessory processor performs a hash function on the received plaintext challenge utilizing the secure authentication image file to generate the cyphertext response.

15. The system of claim 13, wherein the information request command is a timing command, and wherein the information request response comprises a timing response and a timing byte.

16. The system of claim 13, wherein the information request command is a temperature command, and wherein the information request response comprises a temperature response and temperature data.

17. The system of claim 13, wherein the information request command is an identification command, and wherein the information request response comprises an identification response and identification data.

18. The system of claim 13, wherein the transmitting and the receiving steps between the device and the accessory are half duplex communications.

19. The system of claim 13, wherein the device is a wireless communication device and the accessory is a battery for supplying power to the wireless communication device.

* * * * *