

REVISION HISTORY			
REV	DESCRIPTION	APPROVED	DATE

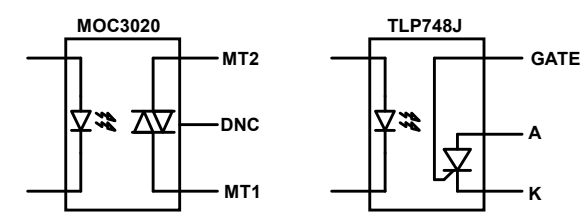
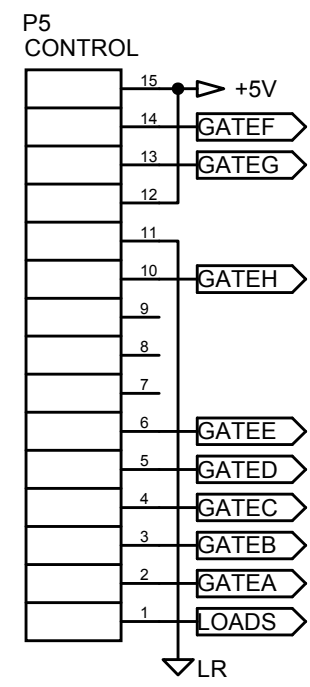
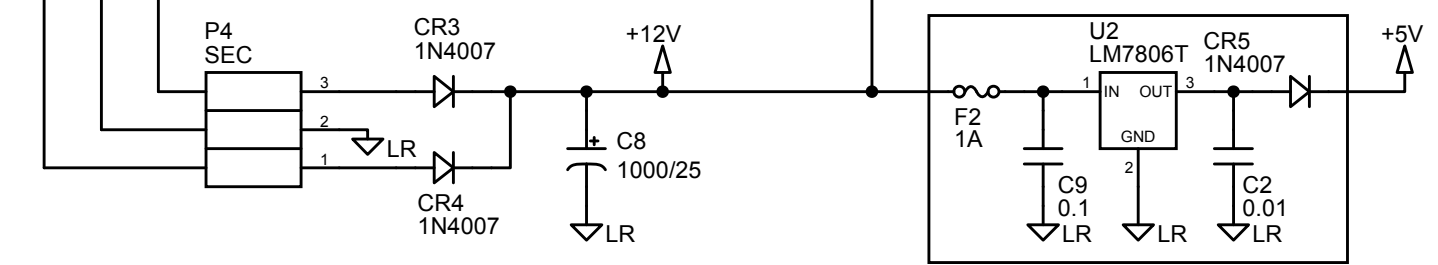
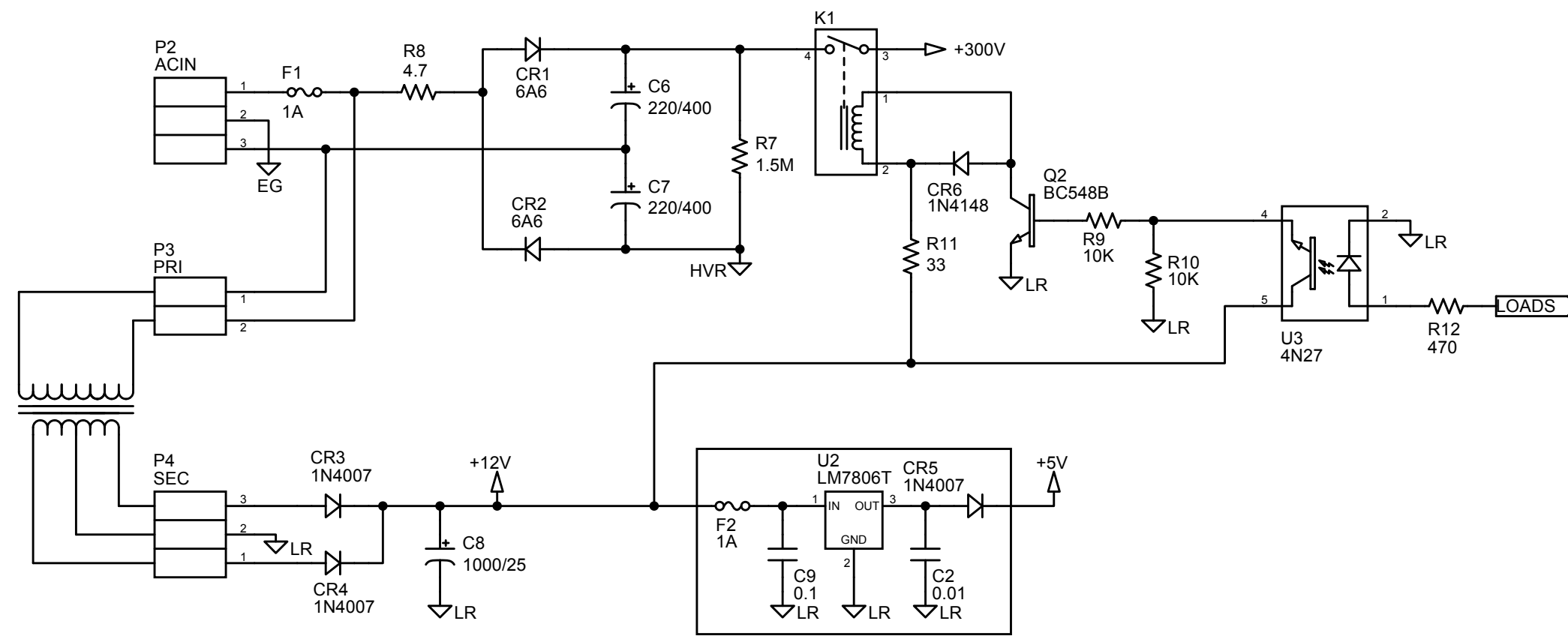

APPROVALS		DATE	TITLE		
DRAWN	J TAYLOR	01/08/12	Psychophotonics strobe power supply and trigger. (See http://www.psychophotonics.com/index.html)		
CHECKED			SIZE	FSCM NO.	DRAWING NO.
ENGINEER			B		power.DSN
PROJ ENGINEER			SCALE	2009 TES	MODIFIED: 01/08/12 11:11:42 AM
APPROVED			NONE		SHEET 1 OF 2
QA					

NOTES: UNLESS OTHERWISE SPECIFIED

REVISION HISTORY			
REV	DESCRIPTION	APPROVED	DATE

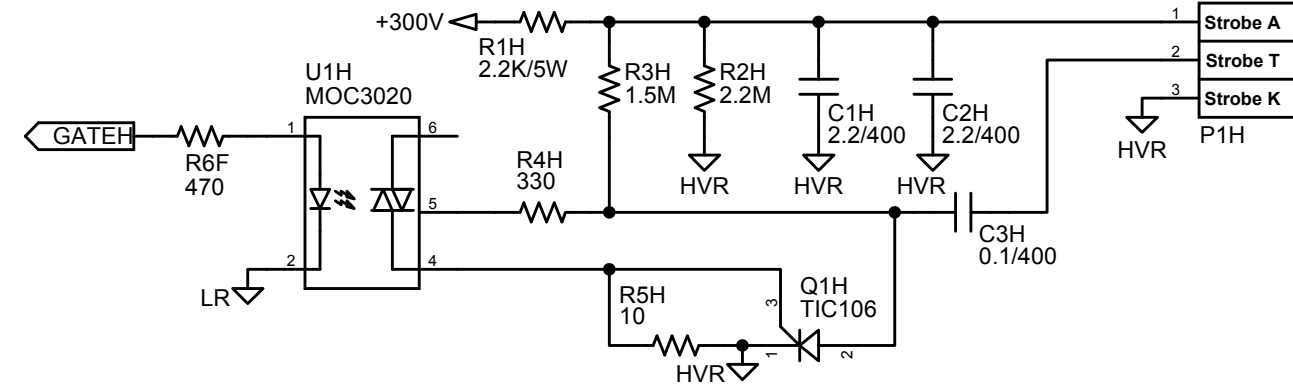
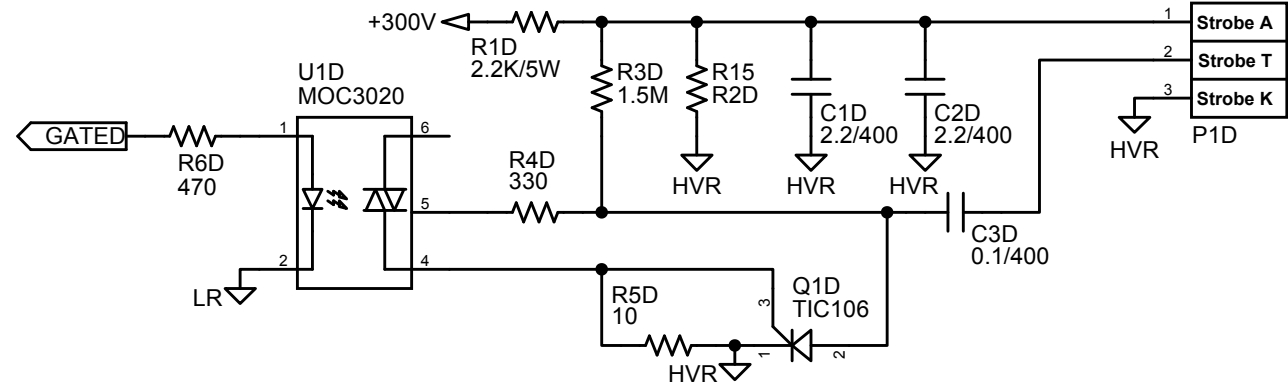
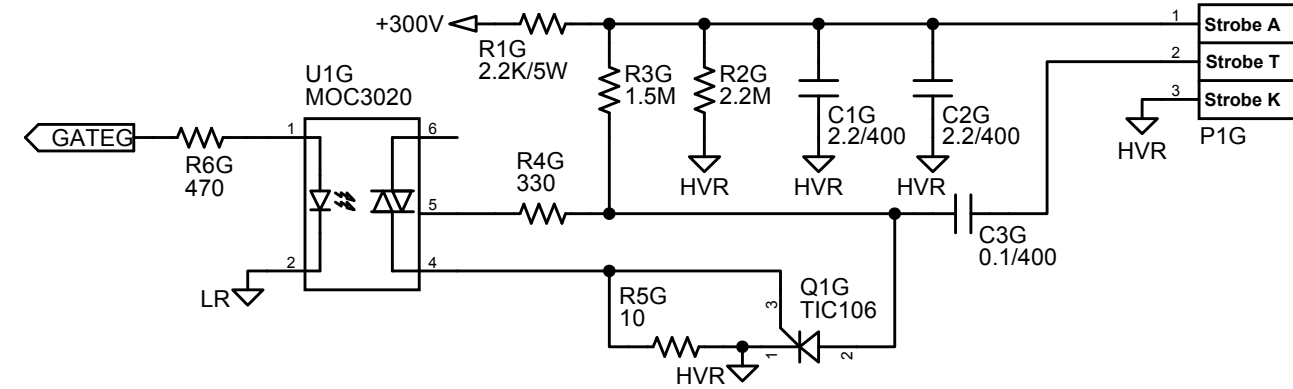
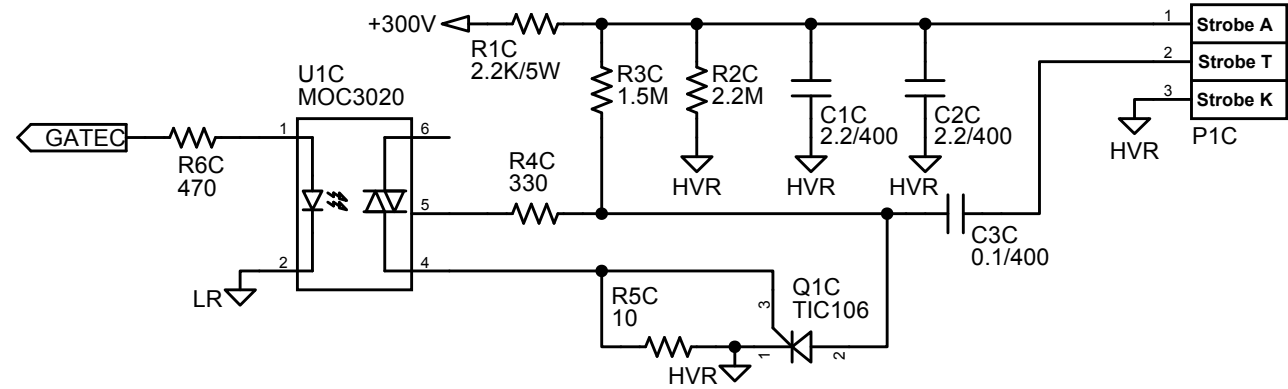
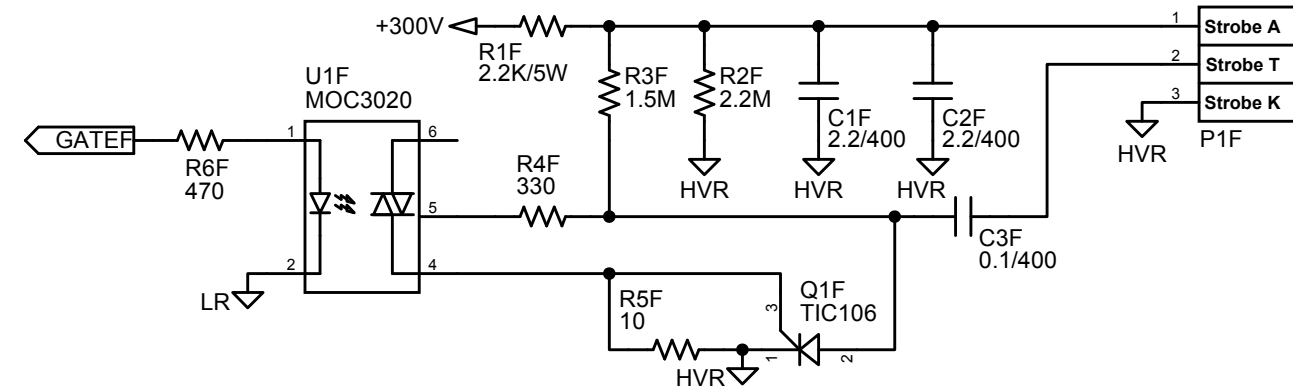
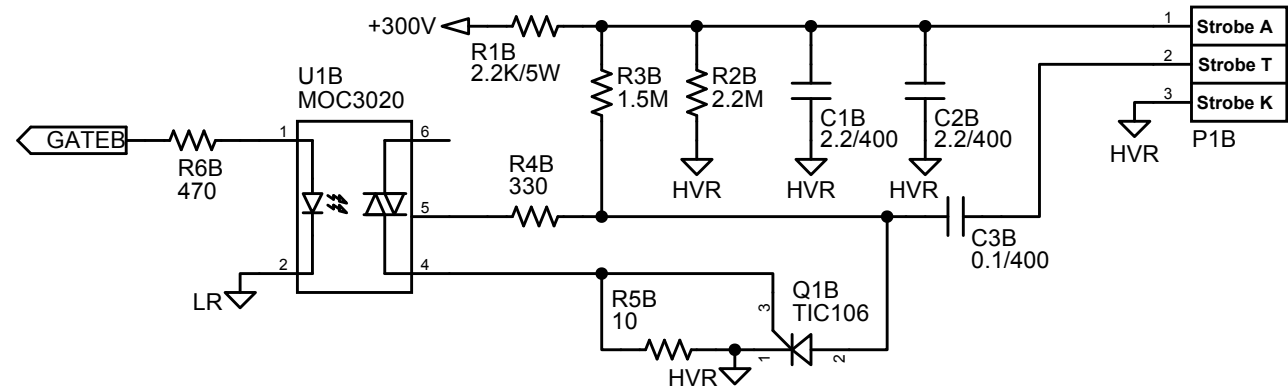
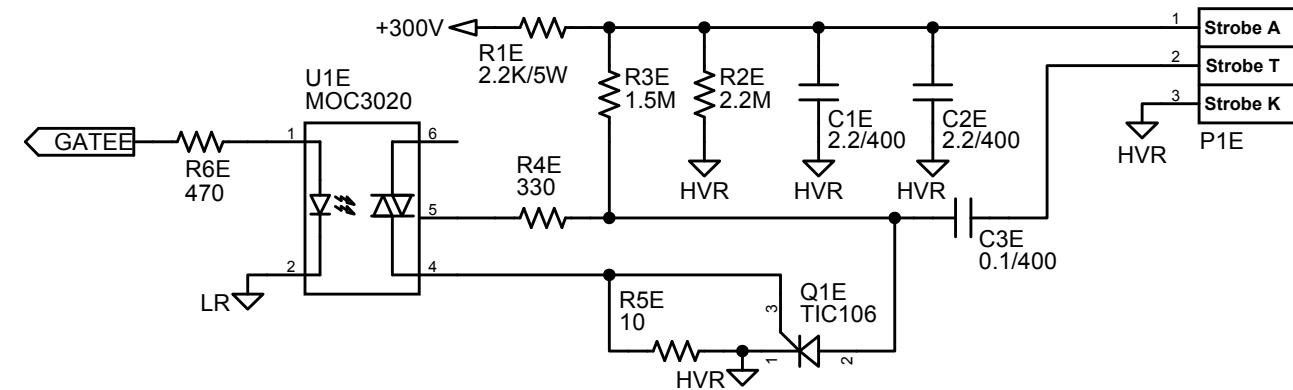
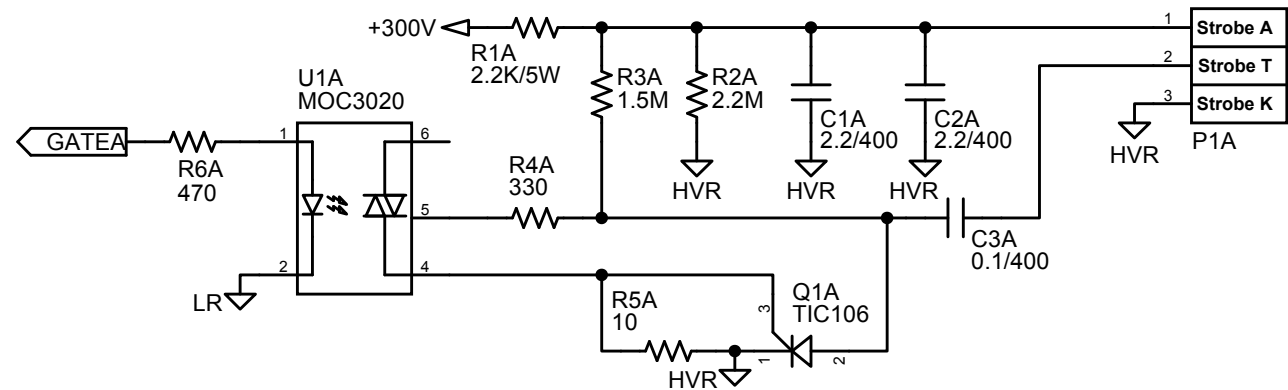

APPROVALS		DATE	TITLE	
DRAWN	J TAYLOR	01/08/12	Psychophotonics strobe power supply and trigger.	
CHECKED				
ENGINEER				
PROJ ENGINEER			SIZE	FSCM NO.
APPROVED			B	DRAWING NO.
QA			SCALE	NONE
			© 2009 TES	MODIFIED: 01/08/12 11:11:42 AM
			SHEET	2 OF 2